



**BAHAGIAN PENGURUSAN SEKOLAH BERASRAMA PENUH  
DAN SEKOLAH KECEMERLANGAN  
KEMENTERIAN PELAJARAN MALAYSIA**

**PEPERIKSAAN PERCUBAAN SPM  
ADDITIONAL MATHEMATICS**

3472 / 1

**Kertas 1  
Ogos 2011  
2 jam**

**Dua jam**

**JANGAN BUKA KERTAS SOALAN INI  
SEHINGGA DIBERITAHU**

1. *Tulis nama dan tingkatan anda pada ruangan yang disediakan.*
2. *Kertas soalan ini adalah dalam dwibahasa.*
3. *Soalan dalam bahasa Inggeris mendahului soalan yang sepadan dalam bahasa Melayu.*
4. *Calon dibenarkan menjawab keseluruhan atau sebahagian soalan sama ada dalam bahasa Inggeris atau bahasa Melayu.*
5. *Calon dikehendaki membaca maklumat di halaman belakang kertas soalan ini.*

<i>Untuk Kegunaan Pemeriksa</i>		
Soalan	Markah Penuh	Markah Diperolehi
1	3	
2	3	
3	3	
4	3	
5	3	
6	3	
7	3	
8	4	
9	4	
10	4	
11	3	
12	3	
13	4	
14	3	
15	3	
16	3	
17	4	
18	2	
19	3	
20	3	
21	3	
22	3	
23	3	
24	3	
25	4	
<b>TOTAL</b>	<b>80</b>	

Kertas soalan ini mengandungi **24** halaman bercetak

**BLANK PAGE**  
***HALAMAN KOSONG***

The following formulae may be helpful in answering the questions. The symbols given are the ones commonly used.

## ALGEBRA

$$1 \quad x = \frac{-b \pm \sqrt{b^2 - 4ac}}{2a}$$

$$2 \quad a^m \times a^n = a^{m+n}$$

$$3 \quad a^m \div a^n = a^{m-n}$$

$$4 \quad (a^m)^n = a^{mn}$$

$$5 \quad \log_a mn = \log_a m + \log_a n$$

$$6 \quad \log_a \frac{m}{n} = \log_a m - \log_a n$$

$$7 \quad \log_a m^n = n \log_a m$$

$$8 \quad \log_a b = \frac{\log_c b}{\log_c a}$$

$$9 \quad T_n = a + (n-1)d$$

$$10 \quad S_n = \frac{n}{2}[2a + (n-1)d]$$

$$11 \quad T_n = ar^{n-1}$$

$$12 \quad S_n = \frac{a(r^n - 1)}{r - 1} = \frac{a(1 - r^n)}{1 - r}, \quad (r \neq 1)$$

$$13 \quad S_\infty = \frac{a}{1 - r}, \quad |r| < 1$$

## CALCULUS

$$1 \quad y = uv, \quad \frac{dy}{dx} = u \frac{dv}{dx} + v \frac{du}{dx}$$

$$2 \quad y = \frac{u}{v}, \quad \frac{dy}{dx} = \frac{v \frac{du}{dx} - u \frac{dv}{dx}}{v^2},$$

$$3 \quad \frac{dy}{dx} = \frac{dy}{du} \times \frac{du}{dx}$$

4 Area under a curve

$$= \int_a^b y \, dx \quad \text{or}$$

$$= \int_a^b x \, dy$$

5 Volume generated

$$= \int_a^b \pi y^2 \, dx \quad \text{or}$$

$$= \int_a^b \pi x^2 \, dy$$

## GEOMETRY

$$1 \quad \text{Distance} = \sqrt{(x_2 - x_1)^2 + (y_2 - y_1)^2}$$

2 Midpoint

$$(x, y) = \left( \frac{x_1 + x_2}{2}, \frac{y_1 + y_2}{2} \right)$$

$$3 \quad |r| = \sqrt{x^2 + y^2}$$

$$4 \quad \hat{r} = \frac{xi + yj}{\sqrt{x^2 + y^2}}$$

5 A point dividing a segment of a line

$$(x, y) = \left( \frac{nx_1 + mx_2}{m + n}, \frac{ny_1 + my_2}{m + n} \right)$$

6 Area of triangle

$$= \frac{1}{2} |(x_1 y_2 + x_2 y_3 + x_3 y_1) - (x_2 y_1 + x_3 y_2 + x_1 y_3)|$$

## STATISTIC

$$1 \quad \bar{x} = \frac{\sum x}{N}$$

$$2 \quad \bar{x} = \frac{\sum fx}{\sum f}$$

$$3 \quad \sigma = \sqrt{\frac{\sum (x - \bar{x})^2}{N}} = \sqrt{\frac{\sum x^2}{N} - \bar{x}^2}$$

$$4 \quad \sigma = \sqrt{\frac{\sum f(x - \bar{x})^2}{\sum f}} = \sqrt{\frac{\sum fx^2}{\sum f} - \bar{x}^2}$$

$$5 \quad m = L + \left[ \frac{\frac{1}{2}N - F}{f_m} \right] C$$

$$6 \quad I = \frac{Q_1}{Q_0} \times 100$$

$$7 \quad \bar{I} = \frac{\sum w_1 I_1}{\sum w_1}$$

$$8 \quad {}^n P_r = \frac{n!}{(n-r)!}$$

$$9 \quad {}^n C_r = \frac{n!}{(n-r)!r!}$$

$$10 \quad P(A \cup B) = P(A) + P(B) - P(A \cap B)$$

$$11 \quad P(X=r) = {}^n C_r p^r q^{n-r}, p + q = 1$$

$$12 \quad \text{Mean } \mu = np$$

$$13 \quad \sigma = \sqrt{npq}$$

$$14 \quad z = \frac{x - \mu}{\sigma}$$

## TRIGONOMETRY

$$1 \quad \text{Arc length, } s = r\theta$$

$$2 \quad \text{Area of sector, } L = \frac{1}{2} r^2 \theta$$

$$3 \quad \sin^2 A + \cos^2 A = 1$$

$$4 \quad \sec^2 A = 1 + \tan^2 A$$

$$5 \quad \operatorname{cosec}^2 A = 1 + \cot^2 A$$

$$6 \quad \sin 2A = 2 \sin A \cos A$$

$$7 \quad \begin{aligned} \cos 2A &= \cos^2 A - \sin^2 A \\ &= 2 \cos^2 A - 1 \\ &= 1 - 2 \sin^2 A \end{aligned}$$

$$8 \quad \tan 2A = \frac{2 \tan A}{1 - \tan^2 A}$$

$$9 \quad \sin(A \pm B) = \sin A \cos B \pm \cos A \sin B$$

$$10 \quad \cos(A \pm B) = \cos A \cos B \mp \sin A \sin B$$

$$11 \quad \tan(A \pm B) = \frac{\tan A \pm \tan B}{1 \mp \tan A \tan B}$$

$$12 \quad \frac{a}{\sin A} = \frac{b}{\sin B} = \frac{c}{\sin C}$$

$$13 \quad a^2 = b^2 + c^2 - 2bc \cos A$$

$$14 \quad \text{Area of triangle} = \frac{1}{2} ab \sin C$$

**THE UPPER TAIL PROBABILITY  $Q(z)$  FOR THE NORMAL DISTRIBUTION  $N(0,1)$   
 KEBARANGKALIAN Hujung ATAS  $Q(z)$  BAGI TABURAN NORMAL  $N(0, 1)$**

z	0	1	2	3	4	5	6	7	8	9	Minus / Tolak								
											1	2	3	4	5	6	7	8	9
0.0	0.5000	0.4960	0.4920	0.4880	0.4840	0.4801	0.4761	0.4721	0.4681	0.4641	4	8	12	16	20	24	28	32	36
0.1	0.4602	0.4562	0.4522	0.4483	0.4443	0.4404	0.4364	0.4325	0.4286	0.4247	4	8	12	16	20	24	28	32	36
0.2	0.4207	0.4168	0.4129	0.4090	0.4052	0.4013	0.3974	0.3936	0.3897	0.3859	4	8	12	15	19	23	27	31	35
0.3	0.3821	0.3783	0.3745	0.3707	0.3669	0.3632	0.3594	0.3557	0.3520	0.3483	4	7	11	15	19	22	26	30	34
0.4	0.3446	0.3409	0.3372	0.3336	0.3300	0.3264	0.3228	0.3192	0.3156	0.3121	4	7	11	15	18	22	25	29	32
0.5	0.3085	0.3050	0.3015	0.2981	0.2946	0.2912	0.2877	0.2843	0.2810	0.2776	3	7	10	14	17	20	24	27	31
0.6	0.2743	0.2709	0.2676	0.2643	0.2611	0.2578	0.2546	0.2514	0.2483	0.2451	3	7	10	13	16	19	23	26	29
0.7	0.2420	0.2389	0.2358	0.2327	0.2296	0.2266	0.2236	0.2206	0.2177	0.2148	3	6	9	12	15	18	21	24	27
0.8	0.2119	0.2090	0.2061	0.2033	0.2005	0.1977	0.1949	0.1922	0.1894	0.1867	3	5	8	11	14	16	19	22	25
0.9	0.1841	0.1814	0.1788	0.1762	0.1736	0.1711	0.1685	0.1660	0.1635	0.1611	3	5	8	10	13	15	18	20	23
1.0	0.1587	0.1562	0.1539	0.1515	0.1492	0.1469	0.1446	0.1423	0.1401	0.1379	2	5	7	9	12	14	16	19	21
1.1	0.1357	0.1335	0.1314	0.1292	0.1271	0.1251	0.1230	0.1210	0.1190	0.1170	2	4	6	8	10	12	14	16	18
1.2	0.1151	0.1131	0.1112	0.1093	0.1075	0.1056	0.1038	0.1020	0.1003	0.0985	2	4	6	7	9	11	13	15	17
1.3	0.0968	0.0951	0.0934	0.0918	0.0901	0.0885	0.0869	0.0853	0.0838	0.0823	2	3	5	6	8	10	11	13	14
1.4	0.0808	0.0793	0.0778	0.0764	0.0749	0.0735	0.0721	0.0708	0.0694	0.0681	1	3	4	6	7	8	10	11	13
1.5	0.0668	0.0655	0.0643	0.0630	0.0618	0.0606	0.0594	0.0582	0.0571	0.0559	1	2	4	5	6	7	8	10	11
1.6	0.0548	0.0537	0.0526	0.0516	0.0505	0.0495	0.0485	0.0475	0.0465	0.0455	1	2	3	4	5	6	7	8	9
1.7	0.0446	0.0436	0.0427	0.0418	0.0409	0.0401	0.0392	0.0384	0.0375	0.0367	1	2	3	4	4	5	6	7	8
1.8	0.0359	0.0351	0.0344	0.0336	0.0329	0.0322	0.0314	0.0307	0.0301	0.0294	1	1	2	3	4	4	5	6	6
1.9	0.0287	0.0281	0.0274	0.0268	0.0262	0.0256	0.0250	0.0244	0.0239	0.0233	1	1	2	2	3	4	4	5	5
2.0	0.0228	0.0222	0.0217	0.0212	0.0207	0.0202	0.0197	0.0192	0.0188	0.0183	0	1	1	2	2	3	3	4	4
2.1	0.0179	0.0174	0.0170	0.0166	0.0162	0.0158	0.0154	0.0150	0.0146	0.0143	0	1	1	2	2	2	3	3	4
2.2	0.0139	0.0136	0.0132	0.0129	0.0125	0.0122	0.0119	0.0116	0.0113	0.0110	0	1	1	1	2	2	2	3	3
2.3	0.0107	0.0104	0.0102		0.00990	0.00964	0.00939	0.00914			0	1	1	1	1	2	2	2	2
				0.00990	0.00964	0.00939	0.00914				3	5	8	10	13	15	18	20	23
								0.00889	0.00866	0.00842	2	5	7	9	12	14	16	16	21
2.4	0.00820	0.00798	0.00776	0.00755	0.00734						2	4	6	8	11	13	15	17	19
						0.00714	0.00695	0.00676	0.00657	0.00639	2	4	6	7	9	11	13	15	17
2.5	0.00621	0.00604	0.00587	0.00570	0.00554	0.00539	0.00523	0.00508	0.00494	0.00480	2	3	5	6	8	9	11	12	14
2.6	0.00466	0.00453	0.00440	0.00427	0.00415	0.00402	0.00391	0.00379	0.00368	0.00357	1	2	3	5	6	7	9	9	10
2.7	0.00347	0.00336	0.00326	0.00317	0.00307	0.00298	0.00289	0.00280	0.00272	0.00264	1	2	3	4	5	6	7	8	9
2.8	0.00256	0.00248	0.00240	0.00233	0.00226	0.00219	0.00212	0.00205	0.00199	0.00193	1	1	2	3	4	4	5	6	6
2.9	0.00187	0.00181	0.00175	0.00169	0.00164	0.00159	0.00154	0.00149	0.00144	0.00139	0	1	1	2	2	3	3	4	4
3.0	0.00135	0.00131	0.00126	0.00122	0.00118	0.00114	0.00111	0.00107	0.00104	0.00100	0	1	1	2	2	2	3	3	4

$$f(z) = \frac{1}{\sqrt{2\pi}} \exp\left(-\frac{1}{2}z^2\right)$$

$$Q(z) = \int_k^{\infty} f(z) dz$$

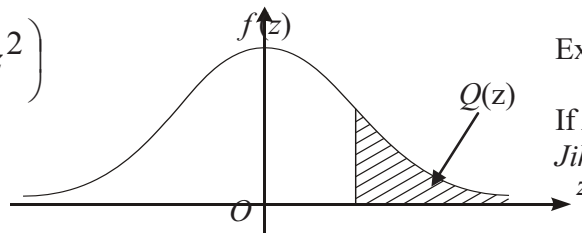

Example / Contoh:

If  $X \sim N(0, 1)$ , then  $P(X > k) = Q(k)$   
 Jika  $X \sim N(0, 1)$ , maka  $P(X > k) = Q(k)$

**SULIT**

For  
examiner's  
use only

Answer **all** questions.  
*Jawab semua soalan.*

1. Diagram 1 shows the function  $f : x \rightarrow \frac{x+3}{x}, x \neq 0$ .  
*Rajah 1 menunjukkan fungsi  $f : x \rightarrow \frac{x+3}{x}, x \neq 0$ .*

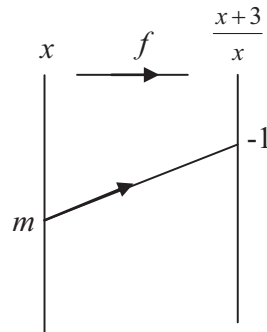

Diagram 1  
*Rajah 1*

Find

*Cari*

- (a) the value of  $m$   
*nilai  $m$*
- (b) image of  $-2$   
*imej bagi  $-2$*

[ 3 marks ]  
[3 markah]

Answer/Jawapan :

(a)

(b)

1

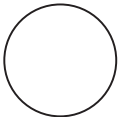
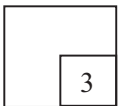

**SULIT****3472/1***For  
examiner's  
use only*

2. Given that the function  $h: x \rightarrow 2x - 3$  dan  $k: x \rightarrow (x - 2)^2 + 1$ .  
Diberi fungsi  $h: x \rightarrow 2x - 3$  dan  $k: x \rightarrow (x - 2)^2 + 1$ .

Find  
Cari

- (a)  $h^{-1}(x)$   
(b)  $h^{-1}k(3)$

[ 3 marks ]  
[3 markah]

Answer/Jawapan :

(a)

(b)

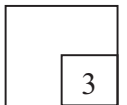
**2**

3. Given that the functions  $f: x \rightarrow ax + b$ ,  $g^{-1}: x \rightarrow \frac{x+5}{2}$  and  $fg^{-1}: x \rightarrow 4 + 3x$ .

Find the value of  $a$  and of  $b$ .

[3 marks]

Diberi fungsi-fungsi  $f: x \rightarrow ax + b$ ,  $g^{-1}: x \rightarrow \frac{x+5}{2}$  and  $fg^{-1}: x \rightarrow 4 + 3x$ .

Cari nilai  $a$  dan nilai  $b$ .

[ 3 markah ]

Answer/Jawapan :

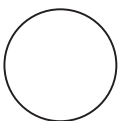
**3**

For  
examiner's  
use only

**SULIT**

4. Find the range of values of  $x$  for  $2x(x+5) \geq x+5$ .

[3 marks]

Cari julat nilai  $x$  bagi  $2x(x+5) \geq x+5$

[ 3 markah ]

Answer/Jawapan :

4



5. The quadratic equation  $px - 1 = 3x^2 - x + p$ , where  $p$  is a constant, has no roots. Find the range of values of  $p$ .

[3 marks]

Persamaan kuadratik  $px - 1 = 3x^2 - x + p$ , dengan keadaan  $p$  ialah pemalar, tidak mempunyai punca.

Cari julat nilai  $p$ .

[ 3 markah ]

Answer/Jawapan :

5

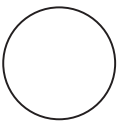
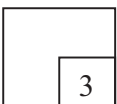



**SULIT****3472/1***For  
examiner's  
use only*

6. Diagram 6 shows the graph of a quadratic function for  $f(x) = 2(x - m)^2 - 3$ .  
*Rajah 6 menunjukkan graf fungsi kuadratik bagi  $f(x) = 2(x - m)^2 - 3$ .*

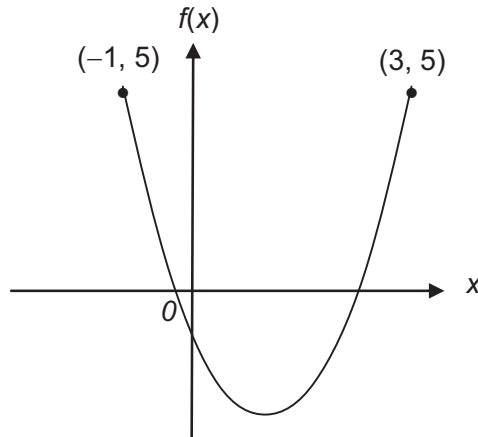

Diagram 6  
*Rajah 6*

Find  
*Cari*

- (a) the value of  $m$ ,  
*nilai  $m$ ,*
- (b) the equation of the axis of symmetry,  
*persamaan paksi simetri,*
- (c) the coordinates of the minimum point.  
*koordinat-koordinat titik minimum.*

[ 3 marks ]  
 [3 markah]

Answer/Jawapan :

(a)

(b)

(c)

6

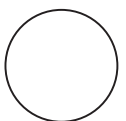
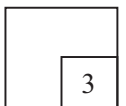

[Lihat halaman sebelah  
**SULIT**

For  
examiner's  
use only

**SULIT**

7. Solve the equation  $\sqrt{25^{x+2}} = \frac{1}{625^{x-1}}$ .

[3 marks]

*Selesaikan persamaan*  $\sqrt{25^{x+2}} = \frac{1}{625^{x-1}}$ .

[ 3 markah ]

Answer/Jawapan :

7



8. Solve the equation  $\log_9 x + \log_{81} 3x = -1$ .

[ 4 marks ]

*Selesaikan persamaan*  $\log_9 x + \log_{81} 3x = -1$ .

[4 markah]

Answer/Jawapan :

8

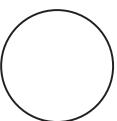

**SULIT****3472/1**

9. The first three terms of an arithmetic progression are  $2h - 4$ ,  $5h - 1$  and  $6h + 4$ .  
*Tiga sebutan pertama suatu jangjang aritmetik adalah  $2h - 4$ ,  $5h - 1$  dan  $6h + 4$ .*

Find,  
*Cari,*

- (a) the value of  $h$ ,  
*nilai  $h$ ,*
- (b) the sum of next 20 terms after the third term.  
*hasil tambah 20 sebutan berikutnya selepas sebutan ketiga.*

[ 4 marks ]  
[4 markah]

Answer/Jawapan :

(a)

(b)

*For  
examiner's  
use only*

9

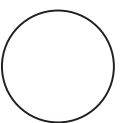

**SULIT**

For  
examiner's  
use only

10. The sum to infinity of a geometric progression is 3 and the sum of its first two terms is  $2\frac{2}{3}$ .

*Hasil tambah hingga sebutan ketak terhinggaan bagi janjang geometri ialah 3 dan hasil tambah dua sebutan pertama ialah  $2\frac{2}{3}$ .*

Find the common ratio ( $r < 0$ ) and the first term.

*Cari nilai nisbah sepunya ( $r < 0$ ) dan sebutan pertama.*

[4 marks]

[4 markah]

Answer/Jawapan

10



11. Aiman saves RM 300 from his salary in a certain month. In each succeeding month, he saves RM 50 more than the previous month.  
*Aiman telah membuat simpanan RM 300 daripada wang gajinya pada bulan tertentu. Pada bulan yang berikutnya, beliau telah menambah simpanannya sebanyak RM 50 melebihi bulan sebelumnya.*

Calculate the amount of his saving in 3 years.

*Hitungkan jumlah simpanan beliau dalam masa 3 tahun.*

[3 marks]

[3 markah]

Answer/Jawapan :

11

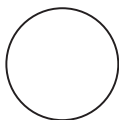

**SULIT****3472/1***For  
examiner's  
use only*

12. The variables  $x$  and  $y$  are related by the equation  $x + \frac{p}{x} = qy$ . A straight line graph is obtained by plotting  $xy$  against  $x^2$ , as shown in Diagram 12, where  $p$  and  $q$  are constants.

*Pemboleh ubah  $x$  dan  $y$  dihubungkan oleh persamaan  $x + \frac{p}{x} = qy$ . Graf garis lurus diperolehi dengan memplot  $xy$  melawan  $x^2$ , seperti ditunjukkan pada Rajah 12, dengan keadaan  $p$  dan  $q$  ialah pemalar.*

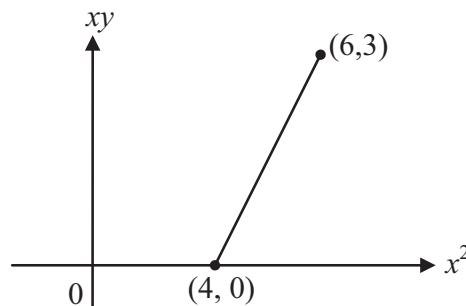
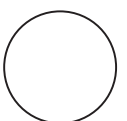
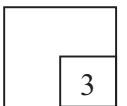

Diagram 12  
Rajah 12

Find the value of  $p$  and of  $q$ .  
*Cari nilai  $p$  dan nilai  $q$ .*

[ 3 marks ]  
[3 markah]

Answer/Jawapan :

**12**

[Lihat halaman sebelah  
**SULIT**

For  
examiner's  
use only

**SULIT**

13. In Diagram 13, the straight line  $PQ$  has an equation  $\frac{x}{8} + \frac{y}{2t} = 1$  with gradient of  $-\frac{1}{4}$ .  $PQ$  intersects the  $x$ -axis at point  $P$  and intersects the  $y$ -axis at point  $Q$ .

Dalam Rajah 13, garis lurus  $PQ$  mempunyai persamaan  $\frac{x}{8} + \frac{y}{2t} = 1$  dengan kecerunan  $-\frac{1}{4}$ .  $PQ$  menyalang paksi- $x$  di titik  $P$  dan menyalang paksi- $y$  di titik  $Q$ .

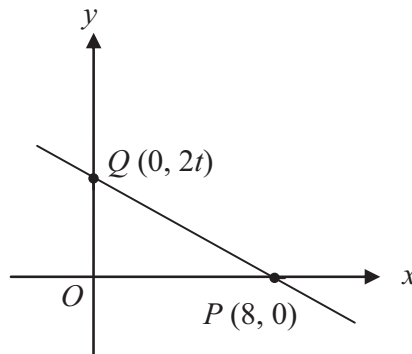

Diagram 13  
Rajah 13

Find,  
Cari,

- (a) the value of  $t$ ,  
nilai bagi  $t$
- (b) the equation of the straight line that passes through  $Q$  and is perpendicular to  $PQ$ .  
persamaan garis lurus yang melalui  $Q$  dan berserenjang dengan  $PQ$ .

[ 4 marks ]

[4 markah]

Answer/Jawapan :

(a)

(b)

13

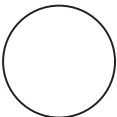
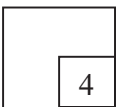

**SULIT****3472/1***For  
examiner's  
use only*

14. Given that the point  $A(-4, 2)$  and  $B(4, 6)$ . The point  $P(-2, 3)$  lies on the straight line of  $AB$  such that  $AP : PB = m : n$ .

*Diberi titik  $A(-4, 2)$  dan  $B(4, 6)$ . Titik  $P(-2, 3)$  terletak pada garislurus  $AB$  dengan keadaan  $AP : PB = m : n$ .*

Find the value of  $m$  and of  $n$ .

*Cari nilai  $m$  dan nilai  $n$ .*

[ 3 marks ]

[3 markah]

Answer/Jawapan :

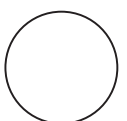
**14**

**SULIT**

For  
examiner's  
use only

15. Diagram 15 shows triangle  $ABC$ .  $K$  is a point on  $BC$  such that  $BK : KC = 1 : 2$ .

Given that  $\overrightarrow{AB} = 3\underline{x}$  and  $\overrightarrow{AC} = 6\underline{y}$ .

Rajah 15 menunjukkan sebuah segitiga  $ABC$ .  $K$  ialah titik yang terletak digaris  $BC$  berkeadaan  $BK : KC = 1 : 2$ . Diberi bahawa  $\overrightarrow{AB} = 3\underline{x}$  dan  $\overrightarrow{AC} = 6\underline{y}$ .

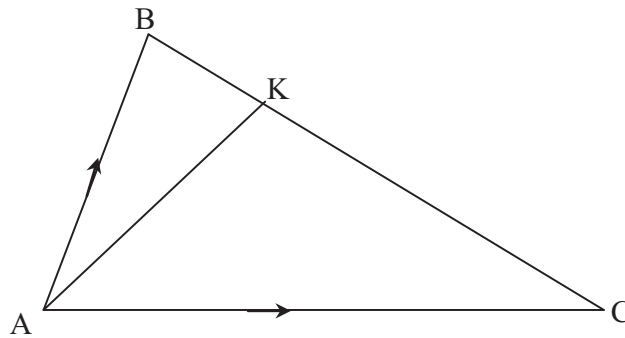

Diagram 15  
Rajah 15

Express in terms of  $\underline{x}$  and  $\underline{y}$ .

Ungkapkan dalam sebutan  $\underline{x}$  dan  $\underline{y}$ ,

- (a)  $\overrightarrow{BC}$   
(b)  $\overrightarrow{AK}$

[ 3 marks ]  
[3 markah]

Answer/Jawapan :

(a)

(b)

15

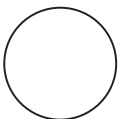
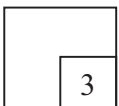



SULIT

3472/1

For  
examiner's  
use only

16. Diagram 16 shows the vector  $\overrightarrow{OP}$  and  $\overrightarrow{OQ}$ .

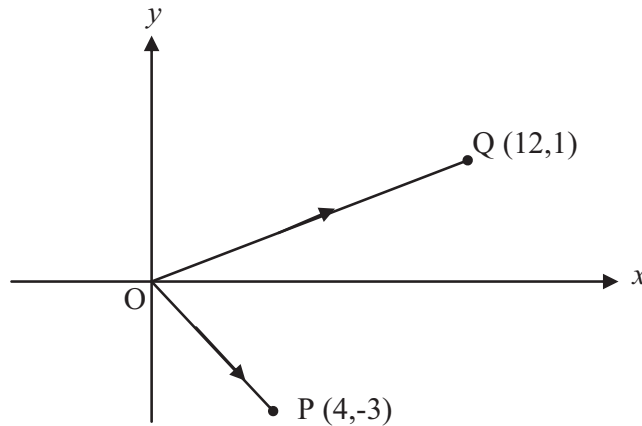

Diagram 16  
Rajah 16

Given that  $O(0,0)$ ,  $P(4,-3)$  and  $Q(12,1)$ , find in terms of  $\underline{i}$  and  $\underline{j}$ ,  
 Diberi bahawa  $O(0,0)$ ,  $P(4,-3)$  and  $Q(12,1)$ , cari dalam sebutan  $\underline{i}$  dan  $\underline{j}$ ,

- (a)  $\overrightarrow{PQ}$   
 (b) the unit vector in the direction of  $\overrightarrow{PQ}$ .  
 vektor unit dalam arah  $\overrightarrow{PQ}$ .

[3 marks ]  
 [3 markah]

Answer/Jawapan :

(a)

(b)

16

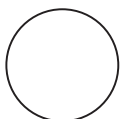

[Lihat halaman sebelah  
 SULIT

For  
examiner's  
use only

**SULIT**

17. Diagram 17 shows sector OAB and sector OCD, with centre O .

Rajah 17 menunjukkan sektor OAB dan sektor OCD, yang berpusatkan O.

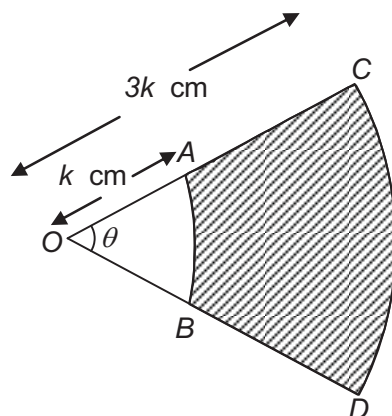

Diagram 17  
Rajah 17

Given that  $\theta = 0.8 \text{ rad}$  and the area of sector OAB is  $40 \text{ cm}^2$ .

Diberi bahawa  $\theta = 0.8 \text{ rad}$  dan luas bagi sektor OAB is  $40 \text{ cm}^2$ .

Find the value of

Cari nilai bagi

- (a)  $k$
- (b) the perimeter of the shaded region.  
perimeter kawasan yang berlorek

[4 marks]  
[4 markah]

Answer/Jawapan :

(a)

(b)

17

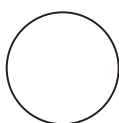

**SULIT****3472/1***For  
examiner's  
use only*

18. Given that  $\sin A = -\frac{12}{13}$  and  $\cos B = \frac{4}{5}$ , where  $A$  and  $B$  are in the same quadrant. Find the value of  $\sin(A - B)$ .

[ 2 marks ]

*Diberi  $\sin A = -\frac{12}{13}$  dan  $\cos B = \frac{4}{5}$ , dimana  $A$  dan  $B$  berada dalam sukuan yang sama. Cari nilai  $\sin(A - B)$ .*

[ 2 markah ]

Answer/Jawapan :

**18**

2

19. Given that  $\int_1^2 f(x) dx = 5$ . Find the value of  $\int_2^1 (x + f(x)) dx$ .

[ 3 marks ]

*Diberi  $\int_1^2 f(x) dx = 5$ . Cari nilai  $\int_2^1 (x + f(x)) dx$ .*

[ 3 markah ]

Answer/Jawapan :

**19**

3

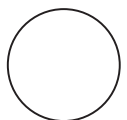

For  
examiner's  
use only

**SULIT**

20. Given that  $y = x^2(x^3 + 4)^3$ , find the value of  $\frac{dy}{dx}$  when  $x = -1$ .

[ 3 marks ]

Diberi  $y = x^2(x^3 + 4)^3$ , cari nilai  $\frac{dy}{dx}$  apabila  $x = -1$ .

[ 3 markah ]

Answer/Jawapan :

20



21. The volume,  $V \text{ cm}^3$  of water in a vessel is given by  $V = 450h - 45h^2$ , where  $h \text{ cm}$  is the height of the water in the vessel.

Isipadu,  $V \text{ cm}^3$  air dalam takungan diberi oleh  $V = 450h - 45h^2$ , dimana  $h \text{ cm}$  ialah tinggi air dalam takungan itu.

Calculate  
Kira

- (a) the value of  $h$  when  $V$  is maximum.  
*nilai  $h$  apabila  $V$  maksimum.*
- (b) the maximum volume of water in the vessel.  
*isipadu maksimum air dalam takungan itu*

[ 3 marks ]  
[ 3 markah ]

Answer/Jawapan :

(a)

21



(b)

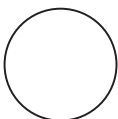

**SULIT****3472/1***For  
examiner's  
use only*

22. A set of positive integers consists of 3, 7,  $p$ , 5, 1 . Given that the mean for the set of data is 5.

*Satu set integer positif mengandungi 3, 7,  $p$ , 5, 1 . Diberi min untuk set data ini ialah 5.*

Find  
Cari

- (a) the value of  $p$ .  
*nilai  $p$ .*
- (b) the variance for the set of data.  
*varian bagi set data ini.*

[ 3 marks ]  
[3 markah]

Answer/Jawapan :

(a)

(b)

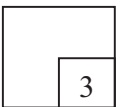
**22**

23. (a) Three letters are chosen from the word "BERHAD" . Calculate the number of different ways in which the three letters can be chosen if there is no restriction.

*Tiga huruf dipilih daripada perkataan "BERHAD" . Hitung bilangan cara berlainan huruf ini boleh dipilih jika tiada sebarang syarat dikenakan.*

- (b) In how many ways can the word "BERHAD" be arranged if the vowel are arranged side by side? .

*Dalam berapa carakah huruf-huruf dalam perkataan "BERHAD" dapat disusun jika huruf vokal hendaklah disusun sebelah menyebelah.*

[ 3 marks ]  
[3 markah]

Answer/Jawapan :

(a)

(b)

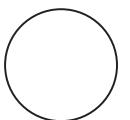
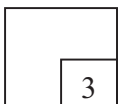
**23**

[Lihat halaman sebelah  
**SULIT**

For  
examiner's  
use only

**SULIT**

24. The probability that Rajesh qualifies for the final 400m event is  $\frac{1}{4}$  while the probability that Razali qualify is  $\frac{1}{3}$ .

*Kebarangkalian bahawa Rajesh layak pertandingan akhir acara 400m ialah  $\frac{1}{4}$  manakala kebarangkalian untuk Razali layak ialah  $\frac{1}{3}$ .*

Find the probability that  
*Hitung kebarangkalian bahawa*

- (a) both of them did not qualify for the final.  
*kedua-dua mereka tidak layak pertandingan akhir.*
- (b) only one of them qualifies for the final.  
*hanya salah seorang daripada mereka layak pertandingan akhir.*

[ 3 marks ]

[3 markah]

Answer/Jawapan :

(a)

(b)

24

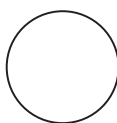

**SULIT****3472/1***For  
examiner's  
use only*

25. Diagram 25 shows a normal distribution graph.  
*Rajah 25 menunjukkan graf taburan normal .*

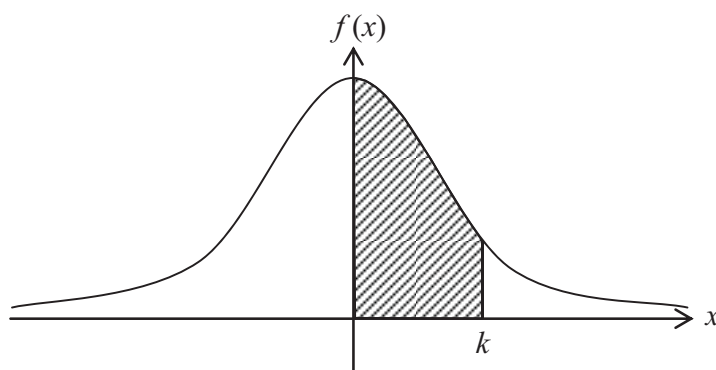

Diagram 25  
*Rajah 25*

$X$  is a continuous random variable which is normally distributed with a mean of 55 kg and a standard deviation of 3 kg.  
Given that the area of the shaded region is 0.3485.

*X ialah pembolehubah rawak selanjur yang tertabur secara normal dengan min 55 kg dan sisihan piawai 3 kg.  
Diberi bahawa luas bagi kawasan berlorek ialah 0.3485.*

Find  
*Cari*

- (a)  $P(X \geq k)$   
(b) the value of  $k$  .  
*nilai bagi  $k$ .*

[ 4 marks ]  
[4 markah]

Answer/*Jawapan* :

- (a)  
  
(b)

25

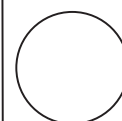

**END OF QUESTION PAPER  
KERTAS SOALAN TAMAT**

**INFORMATION FOR CANDIDATES**  
**MAKLUMAT UNTUK CALON**

1. This question paper consists of **25** questions  
*Kertas soalan ini mengandungi 25 soalan*
2. Answer **all** questions.  
*Jawab semua soalan*
3. Write your answers in the spaces provided in the question paper.  
*Tulis jawapan anda dalam ruang yang disediakan dalam kertas soalan.*
4. Show your working. It may help you to get marks.  
*Tunjukkan langkah-langkah penting dalam kerja mengira anda. Ini boleh membantu anda untuk mendapatkan markah.*
5. If you wish to change your answer, cross out the answer that you have done. Then write down the new answer.  
*Sekiranya anda hendak menukar jawapan, batalkan jawapan yang telah dibuat. Kemudian tulis jawapan yang baru.*
6. The diagrams in the questions provided are not drawn to scale unless stated.  
*Rajah yang mengiringi soalan tidak dilukis mengikut skala kecuali dinyatakan.*
7. The marks allocated for each question are shown in brackets.  
*Markah yang diperuntukkan bagi setiap soalan ditunjukkan dalam kurungan.*
8. A list of formulae is provided on pages 3 to 5.  
*Satu senarai rumus disediakan di halaman 3 hingga 5.*
9. A booklet of four-figure mathematical tables is provided.  
*Sebuah buku sifir matematik empat angka disediakan.*
10. You may use a non-programmable scientific calculator.  
*Anda dibenarkan menggunakan kalkulator saintifik yang tidak boleh diprogram.*
11. Hand in this question paper to the invigilator at the end of the examination.  
*Serahkan kertas soalan ini kepada pengawas peperiksaan di akhir peperiksaan.*



3472/2  
Matematik  
Tambahan  
Kertas 2  
2 ½ jam  
Ogos 2011



**BAHAGIAN PENGURUSAN  
SEKOLAH BERASRAMA PENUH DAN SEKOLAH KECEMERLANGAN  
KEMENTERIAN PELAJARAN MALAYSIA**

---

**PEPERIKSAAN PERCUBAAN  
SIJIL PELAJARAN MALAYSIA 2011**

---

**ADDITIONAL MATHEMATICS**

**Kertas 2**

**Dua jam tiga puluh minit**

---

**JANGAN BUKA KERTAS SOALAN INI SEHINGGA DIBERITAHU**

1. *This question paper consists of three sections : **Section A, Section B and Section C.***
  2. *Answer **all** questions in **Section A** , **four** questions from **Section B** and **two** questions from **Section C.***
  3. *Give only **one** answer / solution to each question.*
  4. *Show your working. It may help you to get marks.*
  5. *The diagram in the questions provided are not drawn to scale unless stated.*
  6. *The marks allocated for each question and sub-part of a question are shown in brackets.*
  7. *A list of formulae and normal distribution table is provided on pages 2 to 4.*
  8. *A booklet of four-figure mathematical tables is provided.*
  9. *You may use a non-programmable scientific calculator.*
- 

Kertas soalan ini mengandungi **20** halaman bercetak

The following formulae may be helpful in answering the questions. The symbols given are the ones commonly used.

## ALGEBRA

$$1 \quad x = \frac{-b \pm \sqrt{b^2 - 4ac}}{2a}$$

$$2 \quad a^m \times a^n = a^{m+n}$$

$$3 \quad a^m \div a^n = a^{m-n}$$

$$4 \quad (a^m)^n = a^{nm}$$

$$5 \quad \log_a mn = \log_a m + \log_a n$$

$$6 \quad \log_a \frac{m}{n} = \log_a m - \log_a n$$

$$7 \quad \log_a m^n = n \log_a m$$

$$8 \quad \log_a b = \frac{\log_c b}{\log_c a}$$

$$9 \quad T_n = a + (n-1)d$$

$$10 \quad S_n = \frac{n}{2}[2a + (n-1)d]$$

$$11 \quad T_n = ar^{n-1}$$

$$12 \quad S_n = \frac{a(r^n - 1)}{r - 1} = \frac{a(1 - r^n)}{1 - r}, \quad (r \neq 1)$$

$$13 \quad S_\infty = \frac{a}{1 - r}, \quad |r| < 1$$

## CALCULUS

$$1 \quad y = uv, \quad \frac{dy}{dx} = u \frac{dv}{dx} + v \frac{du}{dx}$$

$$2 \quad y = \frac{u}{v}, \quad \frac{dy}{dx} = \frac{v \frac{du}{dx} - u \frac{dv}{dx}}{v^2},$$

$$3 \quad \frac{dy}{dx} = \frac{dy}{du} \times \frac{du}{dx}$$

4 Area under a curve

$$= \int_a^b y \, dx \quad \text{or}$$

$$= \int_a^b x \, dy$$

5 Volume generated

$$= \int_a^b \pi y^2 \, dx \quad \text{or}$$

$$= \int_a^b \pi x^2 \, dy$$

## GEOMETRY

$$1 \quad \text{Distance} = \sqrt{(x_1 - x_2)^2 + (y_1 - y_2)^2}$$

2 Midpoint

$$(x, y) = \left( \frac{x_1 + x_2}{2}, \frac{y_1 + y_2}{2} \right)$$

$$3 \quad |r| = \sqrt{x^2 + y^2}$$

$$4 \quad \hat{r} = \frac{xi + yj}{\sqrt{x^2 + y^2}}$$

5 A point dividing a segment of a line

$$(x, y) = \left( \frac{nx_1 + mx_2}{m + n}, \frac{ny_1 + my_2}{m + n} \right)$$

6. Area of triangle =

$$\frac{1}{2} |(x_1 y_2 + x_2 y_3 + x_3 y_1) - (x_2 y_1 + x_3 y_2 + x_1 y_3)|$$

## STATISTIC

$$1 \quad \bar{x} = \frac{\sum x}{N}$$

$$2 \quad \bar{x} = \frac{\sum fx}{\sum f}$$

$$3 \quad \sigma = \sqrt{\frac{\sum (x - \bar{x})^2}{N}} = \sqrt{\frac{\sum x^2}{N} - \bar{x}^2}$$

$$4 \quad \sigma = \sqrt{\frac{\sum f(x - \bar{x})^2}{\sum f}} = \sqrt{\frac{\sum fx^2}{\sum f} - \bar{x}^2}$$

$$5 \quad M = L + \left[ \frac{\frac{1}{2}N - F}{f_m} \right] C$$

$$6 \quad I = \frac{P_1}{P_0} \times 100$$

$$7 \quad \bar{I} = \frac{\sum w_1 I_1}{\sum w_1}$$

$$8 \quad {}^n P_r = \frac{n!}{(n-r)!}$$

$$9 \quad {}^n C_r = \frac{n!}{(n-r)!r!}$$

$$10 \quad P(A \cup B) = P(A) + P(B) - P(A \cap B)$$

$$11 \quad p(X=r) = {}^n C_r p^r q^{n-r}, \quad p + q = 1$$

$$12 \quad \text{Mean, } \mu = np$$

$$13 \quad \sigma = \sqrt{npq}$$

$$14 \quad z = \frac{x - \mu}{\sigma}$$

## TRIGONOMETRY

$$1 \quad \text{Arc length, } s = r\theta$$

$$2 \quad \text{Area of sector, } A = \frac{1}{2}r^2\theta$$

$$3 \quad \sin^2 A + \cos^2 A = 1$$

$$4 \quad \sec^2 A = 1 + \tan^2 A$$

$$5 \quad \operatorname{cosec}^2 A = 1 + \cot^2 A$$

$$6 \quad \sin 2A = 2 \sin A \cos A$$

$$7 \quad \begin{aligned} \cos 2A &= \cos^2 A - \sin^2 A \\ &= 2 \cos^2 A - 1 \\ &= 1 - 2 \sin^2 A \end{aligned}$$

$$8 \quad \tan 2A = \frac{2 \tan A}{1 - \tan^2 A}$$

$$9 \quad \sin(A \pm B) = \sin A \cos B \pm \cos A \sin B$$

$$10 \quad \cos(A \pm B) = \cos A \cos B \mp \sin A \sin B$$

$$11 \quad \tan(A \pm B) = \frac{\tan A \pm \tan B}{1 \mp \tan A \tan B}$$

$$12 \quad \frac{a}{\sin A} = \frac{b}{\sin B} = \frac{c}{\sin C}$$

$$13 \quad a^2 = b^2 + c^2 - 2bc \cos A$$

$$14 \quad \text{Area of triangle} = \frac{1}{2} ab \sin C$$

**THE UPPER TAIL PROBABILITY Q(z) FOR THE NORMAL DISTRIBUTION N(0,1)  
KEBARANGKALIAN Hujung Atas Q(z) BAGI TABURAN NORMAL N(0, 1)**

z	0	1	2	3	4	5	6	7	8	9	Minus / Tolak									
											1	2	3	4	5	6	7	8	9	
0.0	0.5000	0.4960	0.4920	0.4880	0.4840	0.4801	0.4761	0.4721	0.4681	0.4641	4	8	12	16	20	24	28	32	36	
0.1	0.4602	0.4562	0.4522	0.4483	0.4443	0.4404	0.4364	0.4325	0.4286	0.4247	4	8	12	16	20	24	28	32	36	
0.2	0.4207	0.4168	0.4129	0.4090	0.4052	0.4013	0.3974	0.3936	0.3897	0.3859	4	8	12	15	19	23	27	31	35	
0.3	0.3821	0.3783	0.3745	0.3707	0.3669	0.3632	0.3594	0.3557	0.3520	0.3483	4	7	11	15	19	22	26	30	34	
0.4	0.3446	0.3409	0.3372	0.3336	0.3300	0.3264	0.3228	0.3192	0.3156	0.3121	4	7	11	15	18	22	25	29	32	
0.5	0.3085	0.3050	0.3015	0.2981	0.2946	0.2912	0.2877	0.2843	0.2810	0.2776	3	7	10	14	17	20	24	27	31	
0.6	0.2743	0.2709	0.2676	0.2643	0.2611	0.2578	0.2546	0.2514	0.2483	0.2451	3	7	10	13	16	19	23	26	29	
0.7	0.2420	0.2389	0.2358	0.2327	0.2296	0.2266	0.2236	0.2206	0.2177	0.2148	3	6	9	12	15	18	21	24	27	
0.8	0.2119	0.2090	0.2061	0.2033	0.2005	0.1977	0.1949	0.1922	0.1894	0.1867	3	5	8	11	14	16	19	22	25	
0.9	0.1841	0.1814	0.1788	0.1762	0.1736	0.1711	0.1685	0.1660	0.1635	0.1611	3	5	8	10	13	15	18	20	23	
1.0	0.1587	0.1562	0.1539	0.1515	0.1492	0.1469	0.1446	0.1423	0.1401	0.1379	2	5	7	9	12	14	16	19	21	
1.1	0.1357	0.1335	0.1314	0.1292	0.1271	0.1251	0.1230	0.1210	0.1190	0.1170	2	4	6	8	10	12	14	16	18	
1.2	0.1151	0.1131	0.1112	0.1093	0.1075	0.1056	0.1038	0.1020	0.1003	0.0985	2	4	6	7	9	11	13	15	17	
1.3	0.0968	0.0951	0.0934	0.0918	0.0901	0.0885	0.0869	0.0853	0.0838	0.0823	2	3	5	6	8	10	11	13	14	
1.4	0.0808	0.0793	0.0778	0.0764	0.0749	0.0735	0.0721	0.0708	0.0694	0.0681	1	3	4	6	7	8	10	11	13	
1.5	0.0668	0.0655	0.0643	0.0630	0.0618	0.0606	0.0594	0.0582	0.0571	0.0559	1	2	4	5	6	7	8	10	11	
1.6	0.0548	0.0537	0.0526	0.0516	0.0505	0.0495	0.0485	0.0475	0.0465	0.0455	1	2	3	4	5	6	7	8	9	
1.7	0.0446	0.0436	0.0427	0.0418	0.0409	0.0401	0.0392	0.0384	0.0375	0.0367	1	2	3	4	4	5	6	7	8	
1.8	0.0359	0.0351	0.0344	0.0336	0.0329	0.0322	0.0314	0.0307	0.0301	0.0294	1	1	2	3	4	4	5	6	6	
1.9	0.0287	0.0281	0.0274	0.0268	0.0262	0.0256	0.0250	0.0244	0.0239	0.0233	1	1	2	2	3	4	4	5	5	
2.0	0.0228	0.0222	0.0217	0.0212	0.0207	0.0202	0.0197	0.0192	0.0188	0.0183	0	1	1	2	2	3	3	4	4	
2.1	0.0179	0.0174	0.0170	0.0166	0.0162	0.0158	0.0154	0.0150	0.0146	0.0143	0	1	1	2	2	2	3	3	4	
2.2	0.0139	0.0136	0.0132	0.0129	0.0125	0.0122	0.0119	0.0116	0.0113	0.0110	0	1	1	1	2	2	2	3	3	
2.3	0.0107	0.0104	0.0102		0.00990	0.00964	0.00939	0.00914			0	1	1	1	1	2	2	2	2	
											3	5	8	10	13	15	18	20	23	
									0.00889	0.00866	0.00842	2	5	7	9	12	14	16	16	21
2.4	0.00820	0.00798	0.00776	0.00755	0.00734						2	4	6	8	11	13	15	17	19	
						0.00714	0.00695	0.00676	0.00657	0.00639	2	4	6	7	9	11	13	15	17	
2.5	0.00621	0.00604	0.00587	0.00570	0.00554	0.00539	0.00523	0.00508	0.00494	0.00480	2	3	5	6	8	9	11	12	14	
2.6	0.00466	0.00453	0.00440	0.00427	0.00415	0.00402	0.00391	0.00379	0.00368	0.00357	1	2	3	5	6	7	9	9	10	
2.7	0.00347	0.00336	0.00326	0.00317	0.00307	0.00298	0.00289	0.00280	0.00272	0.00264	1	2	3	4	5	6	7	8	9	
2.8	0.00256	0.00248	0.00240	0.00233	0.00226	0.00219	0.00212	0.00205	0.00199	0.00193	1	1	2	3	4	4	5	6	6	
2.9	0.00187	0.00181	0.00175	0.00169	0.00164	0.00159	0.00154	0.00149	0.00144	0.00139	0	1	1	2	2	3	3	4	4	
3.0	0.00135	0.00131	0.00126	0.00122	0.00118	0.00114	0.00111	0.00107	0.00104	0.00100	0	1	1	2	2	2	3	3	4	

$$f(z) = \frac{1}{\sqrt{2\pi}} \exp\left(-\frac{1}{2}z^2\right)$$

$$Q(z) = \int_k^{\infty} f(z) dz$$

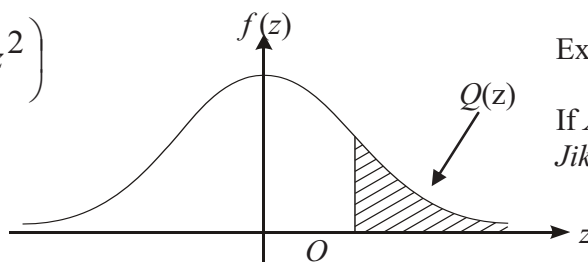

Example / Contoh:

If  $X \sim N(0, 1)$ , then  $P(X > k) = Q(k)$

Jika  $X \sim N(0, 1)$ , maka  $P(X > k) = Q(k)$

**Section A**  
**Bahagian A**

[40 marks]  
[40 markah]

Answer **all** questions.  
Jawab **semua** soalan.

- 1 Solve the following simultaneous equations:  
*Selesaikan persamaan serentak berikut:*

$$4x + 3y = x^2 - xy = 8$$

Give your answer correct to 3 significant figures.  
*Beri jawapan betul kepada 3 angka bererti.*

[5 marks]  
[5 markah]

- 2 (a) Prove that  $\sin(2\theta + 90^\circ) = \cos 2\theta$

[2 marks]

*Buktikan*  $\sin(2\theta + 90^\circ) = \cos 2\theta$

[2 markah]

- (b) i. Sketch the graph of  $y = 2\cos 2\theta$  for  $0 \leq \theta \leq 2\pi$ .

[3 marks]

*Lakar graf bagi of*  $y = 2\cos 2\theta$  *untuk*  $0 \leq \theta \leq 2\pi$ .

[3 markah]

- ii. Hence, using the same axes, sketch a suitable straight line to find the

number of solution for the equation  $\sin(2\theta + 90^\circ) = 1 - \frac{\theta}{\pi}$ .

State the number of solutions.

[3 marks]

*Seterusnya, dengan menggunakan paksi yang sama, lakar satu garis lurus yang sesuai untuk mencari bilangan penyelesaian bagi*

*persamaan*  $\sin(2\theta + 90^\circ) = 1 - \frac{\theta}{\pi}$ .

*Nyatakan bilangan penyelesaian itu.*

[3 markah]

[ **Lihat halaman sebelah**  
**SULIT** ]

- 3 Ravi and Hamid were given a piece of wire each, it is to be bend into several parts successively as shown in Diagram 3.

*Ravi dan Hamid diberi seutas dawai seorang untuk dibengkokkan kepada beberapa bahagian berturut-turut seperti yang ditunjukkan dalam Rajah 3.*



Diagram 3  
Rajah 3

The first part must be measured  $A$  cm and every part should be shortened by  $D$  cm respectively.  
Ravi's wire which is 720 cm was bent exactly into 10 parts and Hamid's which is 1040 cm was bent exactly 20 parts.

*Bahagian pertama mesti berukuran  $A$  cm and setiap bahagian seterusnya dipendekkan sebanyak  $D$  cm masing-masing.  
Dawai Ravi, yang panjangnya 720 cm dibengkokkan tepat kepada 10 bahagian dan Dawai Hamid, yang panjangnya 1040 cm dibengkokkan tepat kepada 20 bahagian.*

Calculate,  
Hitung,

- (a) the value of  $A$  and of  $D$ ,  
*nilai bagi  $A$  dan nilai bagi  $D$ .* [4 marks]  
[4 markah]
- (b) the difference of the length of the last part of the both wire.  
*beza di antara panjang bahagian terakhir bagi kedua-dua dawai tersebut.* [2 marks]  
[2 markah]

4. Diagram 4 shows the straight line  $y = x + 9$  intersecting the curve  $y = (x - 3)^2$  at points  $M$  and  $N(7, 16)$ .

Rajah 4 menunjukkan garis lurus  $y = x + 9$  bersilang dengan lengkung  $y = (x - 3)^2$  pada titik-titik  $M$  dan  $N(7, 16)$ .

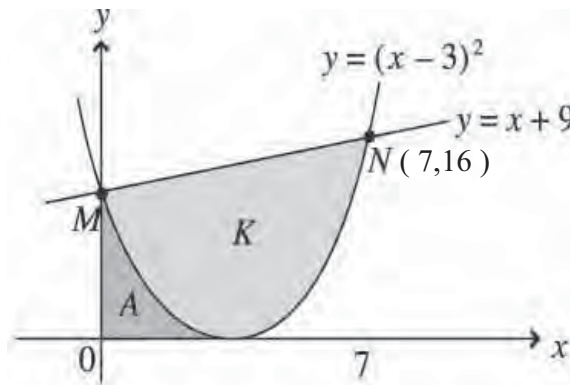

Diagram 4  
Rajah 4

Find  
Cari

- (a) the area of the shaded region  $K$ ,

[4 marks]

luas rantau berlorek  $K$ ,

[4 markah]

- (b) the volume generated when the shaded region  $A$  is rotated through  $360^\circ$  about  $x$ -axis.

[3 marks]

isipadu janaan apabila rantau berlorek  $A$  diputar  $360^\circ$  pada paksi- $x$ .

[3 markah]

5. Solution by scale drawing will **not** be accepted.  
 Penyelesaian secara lukisan berskala **tidak** akan diterima.

Diagram 5 shows quadrilateral  $PQRS$ .  
 Rajah 5 menunjukkan sisi empat  $PQRS$ .

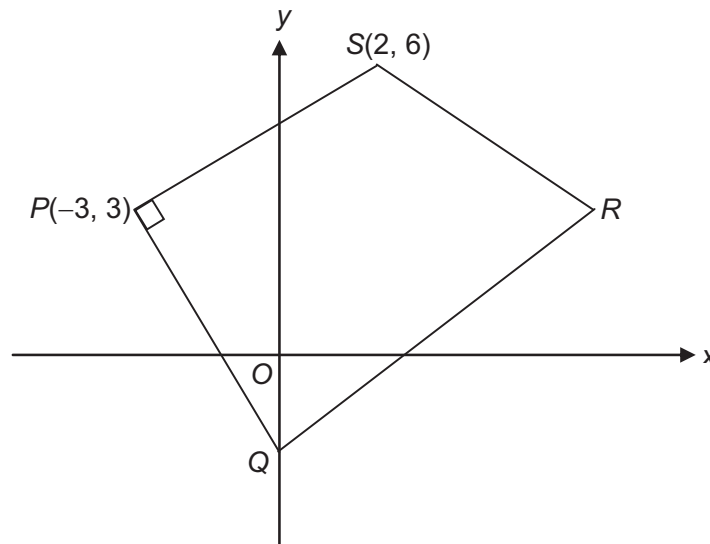

**Diagram 5**  
**Rajah 5**

Given that the coordinates of point  $P(-3, 3)$  and point  $S(2, 6)$ .  
 Diberi bahawa koordnat bagi titik  $P(-3, 3)$  dan titik  $S(2, 6)$ .

- (a) Find the equation of  $PQ$ ,

[3 marks]

Cari persamaan garis lurus  $PQ$ ,

[3 markah]

- (b) A point  $W$  moves such that its distance from point  $Q$  is always twice its distance from point  $S$ . Find the equation of the locus of point  $W$ .

[4 marks]

Titik  $W$  bergerak dengan keadaan jaraknya dari titik  $Q$  adalah sentiasa dua kali jaraknya dari titik  $S$ . Cari persamaan locus bagi  $W$ .

[4 markah]



6. Table 6 shows the marks obtained by a group of students in a class.

Marks	Number of students
25 – 39	10
40 – 54	15
55 – 69	$k$
70 – 84	16
85 – 99	6

Table 6  
Jadual 6

- (a) Given that the median mark of a student is  $60\frac{7}{26}$ , find the value of  $k$

[3 marks]

Diberi markah median pelajar ialah  $60\frac{7}{26}$ , cari nilai bagi  $k$

[3 marks]

- (b) Calculate the standard deviation of the distribution.

[3 marks]

*Kira sisihan piawai taburan tersebut.*

[ 3 marks ]

- (c) If each marks of the students in the class is multiplied by 2 and then subtracted by 3. For the new set of marks, find the standard deviation.

*Jika setiap markah pelajar dalam kelas didarab dengan 2 dan kemudian di tolak dengan 3. Bagi set baru markah, cari sisihan piawai.*

[1 mark]

[1 markah]

**Section B**  
**Bahagian B**

[40 marks]  
[40 markah]

Answer any **four** questions from this section.  
*Jawab mana-mana empat soalan daripada bahagian ini.*

- 7 Use graph paper to answer this questions.  
*Gunakan kertas graf untuk menjawab soalan ini.*

Table 7 shows the values of two variables  $x$  and  $y$  obtained from an experiment. Variable  $x$  and  $y$  are related by equation  $y = pk^{x^2}$ , where  $k$  and  $p$  are constants.

*Jadual 7 menunjukkan nilai-nilai bagi dua pembolehubah,  $x$  dan  $y$ , yang diperolehi daripada satu eksperimen. Pembolehubah  $x$  and  $y$  dihubungkan oleh persamaan  $y = pk^{x^2}$ , dengan keadaan  $k$  dan  $p$  adalah pemalar.*

$x$	0.5	0.7	0.9	1.0	1.2
$y$	4	7	13	20	50

**Table 7**  
**Jadual 7**

- (a) Plot  $\log_{10} y$  against  $x^2$ , using a scale of 2 cm to 0.2 unit on both axes. Hence, draw the line of best fit.

[6 marks]

*Plot  $\log_{10} y$  melawan  $x$ , dengan menggunakan skala 2 cm mewakili 0.2 unit pada kedua-dua paksi.*

*Seterusnya, lukis garis lurus penyuaian terbaik.*

[6 markah]

- (b) Use your graph in 7(a) to find the value of  
*Gunakan graf anda di 7(a) untuk mencari nilai*

- (i)  $k$   
(ii)  $p$   
(iii)  $x$  when  $y = 10$   
 *$x$  apabila  $y = 10$*

[4 marks]

[4 markah]

8. (a) Given that the equation of the curve  $y = 3x^2 + 4x - 2$  is passing through point  $(-1, 3)$ .

*Diberi bahawa persamaan lengkung  $y = 3x^2 + 4x - 2$  melalui titik  $(-1, 3)$ .*

Find  
Cari

- (i) the equation of normal to the curve at point  $(-1, 3)$ . [3 marks]  
*persamaan normal kepada lengkung pada titik  $(-1, 3)$ .* [3 markah]

- (ii) the approximate value in  $y$ , when  $x$  decrease from 2 to 1.99. [3 marks]  
*nilai hampir bagi  $y$ , apabila  $x$  menyusut dari 2 kepada 1.99.* [3 markah]

- (b) Given that the gradient function of a curve  $\frac{8-x^3}{2x^5}$  which has a turning point at  $(p, 3)$ .

*Diberi bahawa fungsi kecerunan kepada lengkung  $\frac{8-x^3}{2x^5}$  yang mempunyai titik pusingan pada titik  $(p, 3)$ .*

Find  
Cari

- (i) the value of  $p$  [4 marks]  
*nilai  $p$ .*
- (ii) the equation of the curve. [ 4 markah ]  
*persamaan lengkung itu.*

- 9 Diagram 10 shows triangles OAB and APR.  
*Rajah 10 menunjukkan segi tiga OAB dan APR.*

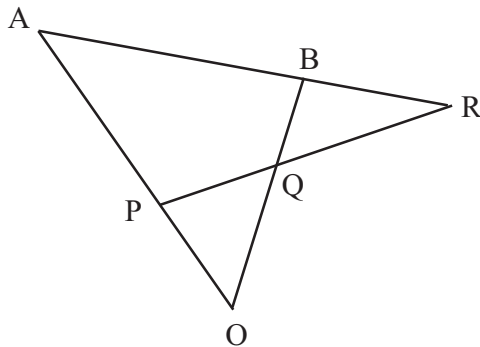

**Diagram 10**  
**Rajah 10**

OPA, OQB, PQR and ABR are straight lines.  
 Given  $\vec{OA} = \underline{a}$ ,  $\vec{OB} = 2\underline{b}$ ,  $3\vec{OP} = \vec{OA}$  and  $2\vec{OQ} = \vec{OB}$ .

OPA, OQB, PQR dan ABR ialah garislurus.  
 Diberi  $\vec{OA} = \underline{a}$ ,  $\vec{OB} = 2\underline{b}$ ,  $3\vec{OP} = \vec{OA}$  dan  $2\vec{OQ} = \vec{OB}$

- (a) Express each of the following vectors in terms of  $\underline{a}$  and/ or  $\underline{b}$ .

*Ungkapkan dalam sebutan  $\underline{a}$  dan/ atau  $\underline{b}$ .*

- (i)  $\vec{AB}$
- (ii)  $\vec{PQ}$

[3 marks]  
 [3 markah]

- (b) Given  $\vec{AR} = m\vec{AB}$  and  $\vec{QR} = n\vec{PQ}$ , where  $m$  and  $n$  are constants.

*Diberi  $\vec{AR} = m\vec{AB}$  dan  $\vec{QR} = n\vec{PQ}$ , dengan keadaan  $m$  dan  $n$  ialah pemalar.*

Express  $\vec{OR}$  in terms of  
*Ungkapkan  $\vec{OR}$  dalam sebutan*

- (i)  $m$ ,  $\underline{a}$  and  $\underline{b}$ ,
- $m$ ,  $\underline{a}$  dan  $\underline{b}$ ,
- (ii)  $n$ ,  $\underline{a}$  and  $\underline{b}$ .
- $n$ ,  $\underline{a}$  dan  $\underline{b}$ .

[4 marks]  
 [4 markah]

- (c) Hence, find the value of  $m$  and of  $n$ .  
*Seterusnya, cari nilai  $m$  dan nilai  $n$ .*

[3 marks]  
 [ 3 markah ]

- 10 (a) At SMK Bandar Baru, 30 out of 120 form 4 students cycle to school. If 10 students are chosen at random, calculate the probability that

*Di SMK Bandar Baru, 30 daripada 120 orang pelajar tingkatan 4 mengayuh basikal ke sekolah. Jika 10 orang pelajar dipilih secara rawak, hitung kebarangkalian bahawa*

- (i) exactly 2 of them cycle to school  
*tepat 2 orang pelajar mengayuh basikal ke sekolah.*
- (ii) more than 2 students cycle to school  
*lebih daripada 2 orang pelajar mengayuh basikal ke sekolah.*

[4 marks]

[4 markah]

- (b) In a fresh water fish pond, the weight of one type of fish is normally distributed with a mean of 1.0 kg and a standard deviation of 0.3 kg.

*Dalam sebuah kolam ikan air tawar, berat sejenis ikan adalah tertabur secara normal dengan min 1.0 kg dan sisihan piawai 0.3 kg.*

- (i) Find the probability of a fish chosen randomly which is less than 0.8 kg.  
*Cari kebarangkalian bahawa seekor ikan yang dipilih secara rawak mempunyai berat kurang daripada 0.8 kg.*

- (ii) If there are 100 fish which has weight less than 0.8 kg, find the total number of fish in the pond.  
*Jika terdapat 100 ekor ikan yang mempunyai berat kurang daripada 0.8 kg, cari jumlah ikan di dalam kolam itu.*

- (iii) Given that 20% of the fish has the weight more than  $m$  kg. Find the value of  $m$ .

*Diberi bahawa 20% daripada ikan tersebut mempunyai berat lebih daripada  $m$  kg. Cari nilai bagi  $m$ .*

[6 marks]

[6 markah]

- 11 Diagram 11 shows a semicircle  $ABE$  and a sector  $OCD$ , with centre  $O$ .  
*Rajah 11 menunjukkan semibulatan  $ABE$  dan sektor  $OCD$ , yang berpusatkan  $O$ .*

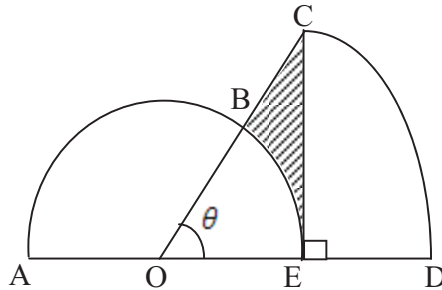

Diagram 11  
*Rajah 11*

Given that the length of  $AE = 16$  cm and  $OB : BC = 2 : 1$ .  
*Diberi bahawa panjang  $AE = 16$  cm dan  $OB : BC = 2 : 1$ .*  
 [Use  $\pi = 3.142$ ]  
 [Guna  $\pi = 3.142$ ]

Calculate  
*Hitung*

- (a)  $\theta$ , in radian.  
 *$\theta$ , dalam radian.* [3 marks]  
 [3 markah]
- (b) the area, in  $\text{cm}^2$ , of the shaded region,  
*luas, dalam  $\text{cm}^2$ , bagi kawasan berlorek,.* [3 marks]  
 [3 markah]
- (c) perimeter, in cm, for the whole diagram.  
*perimeter, dalam cm, untuk seluruh rajah.* [4 marks]  
 [4 markah]

**Section C**  
**Bahagian C**

[20 marks]  
[20 markah]

Answer any **two** questions from this section.  
*Jawab mana-mana dua soalan daripada bahagian ini.*

12. A particle moves along a straight line from a fixed point O, which is situated 3 meters on the right of point O. Its velocity,  $V \text{ ms}^{-1}$  is given by  $v = t^2 - 8t + 12$ , where  $t$  is the time in seconds, after leaving O.

*Suatu zarah bergerak disepanjang suatu garis lurus daripada satu titik tetap O yang berada 3 meter di kanan O. Halajunya,  $V \text{ ms}^{-1}$ , diberi oleh  $v = t^2 - 8t + 12$ , dengan keadaan  $t$  ialah masa dalam saat selepas melalui O.*

[Assume motion to the right is positive]  
[Anggapkan gerakan ke arah kanan sebagai positif]

Find  
Cari

- (a) (i) the minimum velocity, [2 marks]  
*halaju minimum,* [2 markah]
- (ii) the range of values of  $t$  when the particle moving to the left, [ 3 marks ]  
*julat nilai  $t$  apabila zarah bergerak ke kiri,* [ 3 markah ]
- (b) Sketch the velocity-time graph for  $0 \leq t \leq 5$ .  
Hence or otherwise calculate the total distance travelled during the first 5 seconds after leaving O. [5 marks]
- Lakarkan graf halaju-masa untuk  $0 \leq t \leq 5$ .  
Seterusnya atau dengan cara lain hitung jumlah jarak yang dilalui dalam 5 saat yang pertama selepas melalui O.* [5 markah]

[ Lihat halaman sebelah  
**SULIT** ]

- 13 Diagram 13 shows two triangles  $ACD$  and  $DBC$ , where  $AEC$  and  $BED$  are straight lines.

Rajah 13 menunjukkan segitiga  $ACD$  dan  $DBC$  di mana  $AEC$  dan  $BED$  adalah garis lurus.

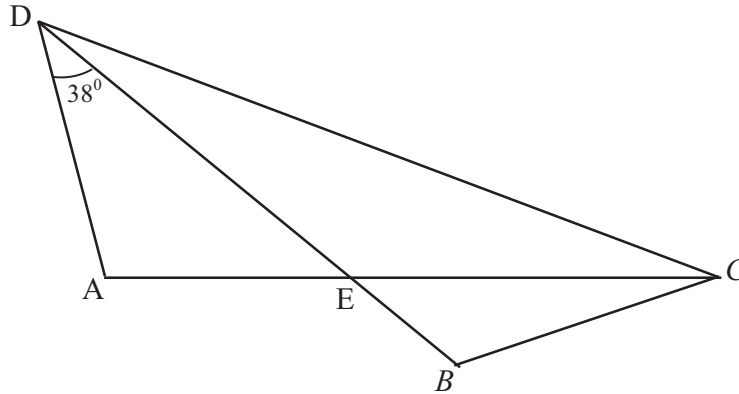

Diagram 13  
Rajah 13

Given that  $AE = 5$  cm,  $AD = 4$  cm,  $EC = 8$  cm,  $\angle ADE = 38^\circ$ , and  $\angle DEC$  is an obtuse angle.

Diberi bahawa  $AE = 5$  cm,  $AD = 4$  cm,  $EC = 8$  cm,  $\angle ADE = 38^\circ$ , dan  $\angle DEC$  ialah sudut cakah.

Calculate  
Kira

- (a) (i)  $\angle DEC$  [3 marks]  
[3 markah]
- (ii) the length of  $DC$  [3 marks]  
panjang  $DC$  [3 markah]
- (iii) the area of the triangle  $ADC$ . [2 marks]  
luas segitiga  $ADC$ . [2 markah]
- (b) Sketch triangle  $C'B'D'$  which has a different shape from triangle  $CBD$  such that  $D'C' = DC$ ,  $B'C' = BC$  and  $\angle C'D'B' = \angle CDB$ . [2 marks]

Lakar segitiga  $C'B'D'$  yang mempunyai bentuk yang berlainan dengan segitiga  $CBD$  dengan keadaan  $D'C' = DC$ ,  $B'C' = BC$  dan  $\angle C'D'B' = \angle CDB$ .

[2 markah]



- 14 Use the graph paper provided to answer this question.  
Gunakan kertas graf yang disediakan untuk menjawab soalan ini.

Mr. Ridhuan intends to plant banana trees and papaya trees on a piece of 80 hectares land. He employed 360 labours and allocated a capital of at least RM 24 000. Mr. Ridhuan used  $x$  hectares of land to plant banana trees and  $y$  hectares to plant papaya trees. Each hectare of banana trees farm is supervised by 3 labours while each hectare of papaya trees farm is supervised by 6 labours. The cost of consumption for a hectare of banana trees farm are RM 800 and a hectare of papaya trees farm are RM 300.

*En. Ridhuan ingin menanam pokok pisang dan pokok betik di atas sebidang tanah seluas 80 hektar. Dia mempunyai 360 orang tenaga pekerja dan modal sekurang-kurangnya RM 24 000. En. Ridhuan menggunakan  $x$  hektar tanah untuk menanam pokok pisang dan  $y$  hektar tanah untuk menanam pokok betik. Setiap hektar ladang pokok pisang diselia oleh tiga orang pekerja sementara enam orang pekerja untuk setiap hektar ladang pokok betik. Kos perbelanjaan untuk sehektar ladang pokok pisang ialah RM 800 dan sehektar ladang pokok betik ialah RM 300.*

- (a) State three inequalities, other than  $x \geq 0$  and  $y \geq 0$  which satisfy the above conditions.

*Nyatakan tiga ketaksamaan selain  $x \geq 0$  dan  $y \geq 0$  yang memuaskan syarat-syarat di atas.*

[3 marks]

[3 markah]

- (b) Using the scale of 2 cm to 10 hectares on both axes, draw and shade a region  $R$  which satisfies all of the above conditions.

*Dengan menggunakan skala 2 cm kepada 10 hektar pada kedua-dua paksi, lukis dan lorekkan rantau  $R$  yang memuaskan semua syarat-syarat di atas.*

[3 marks]

[3 markah]

- (c) Based on your graph, answer the following questions:

*Berdasarkan graf anda, jawab soalan-soalan berikut :*

- (i) If the area of land allocated for planting banana trees is twice the land for papaya trees, find the maximum area of land for each type of fruit.

*Jika luas kawasan tanah untuk menanam pokok pisang adalah 2 kali luas kawasan tanah untuk menanam pokok betik, cari keluasan maksimum tanah yang digunakan untuk menanam setiap tanaman.*

- (ii) The profit gained by selling bananas are RM 700 and by selling papayas are RM 250 for each hectare. Find the minimum profit gained.

*Keuntungan hasil jualan pisang ialah RM 700 dan hasil jualan betik ialah RM 250 bagi setiap hektar. Cari keuntungan minimum yang diperolehi.*

[4 marks]

[4 markah]

[ Lihat halaman sebelah

SULIT

15. Table 15 shows the price indices of the monthly expenditures for Muhammad's family in the year 2000 based on the year 1996, the change in price index from the year 2000 to the year 2004 and the percentage of expenditure respectively.

*Jadual 15 menunjukkan indeks harga bagi perbelanjaan bulanan keluarga Muhammad pada tahun 2000 berdasarkan tahun 1996, perubahan indeks harga dari tahun 2000 ke tahun 2004 dan peratus perbelanjaan masing-masing.*

Expenditure Perbelanjaan	Price index in the year 2000 <i>Indeks harga pada tahun 2000</i>	Change of price index from the year 2000 to the year 2004 <i>Perubahan indeks harga dari tahun 2000 ke tahun 2004</i>	Percentage of expenditure (%) <i>Peratus perbelanjaan (%)</i>
<i>P</i>	110	Increased 15 %	<i>x</i>
<i>Q</i>	120	Decreased 10 %	30
<i>R</i>	125	Unchanged	<i>y</i>
<i>S</i>	150	Unchanged	15

Table 15  
*Jadual 15*

- (a) Calculate the expenditure of item *P* in the year 1996 if its expenditure in the year 2000 is RM 150.65.  
*Hitungkan perbelanjaan bagi item P pada tahun 1996 jika perbelanjaannya pada tahun 2000 ialah RM 150.65.*

[2 marks]  
[2 markah]

- (b) The composite index number in the year 2000 based on the year 1996 is 121.25.  
*Nombor indeks gubahan pada tahun 2000 berdasarkan tahun 1996 ialah 121.25.*

Calculate  
*Hitungkan*

- (i) the value of *x* and of *y*,  
nilai *x* dan nilai *y*,
- (ii) the total monthly expenditure in the year 2000 if the total monthly expenditure for Muhammad's family in the year 1996 is RM 260.  
*jumlah perbelanjaan pada tahun 2000 jika perbelanjaan keluarga Muhammad pada tahun 1996 ialah RM 260.*

[5 marks]  
[5 markah]

- (c) Find the composite index number in the year 2004 based on the year 1996.  
*Cari nombor indeks gubahan pada tahun 2004 berdasarkan tahun 1996.*

[3 marks]  
[3 markah]

**END OF QUESTION PAPER**  
**KERTAS SOALAN TAMAT**

**INFORMATION FOR CANDIDATES**  
**MAKLUMAT UNTUK CALON**

- 1 This question paper consists of three sections : **Section A, Section B** and **Section C**.  
*Kertas soalan ini mengandungi tiga bahagian Bahagian A, Bahagian B dan Bahagian C*
- 2 Answer **all** questions in **Section A**, **four** questions from **Section B** and **two** questions from **Section C**.  
*Jawab semua soalan dalam Bahagian A, mana-mana empat soalan daripada Bahagian B dan mana-mana dua soalan daripada Bahagian C*
- 3 Write your answer on the ‘buku jawapan’ provided. If the buku jawapan is insufficient, you may ask for ‘helaian tambahan’ from the invigilator.  
*Jawapan anda hendaklah ditulis di dalam buku jawapan yang disediakan. Sekiranya buku jawapan tidak mencukupi, sila dapatkan helaian tambahan daripada pengawas peperiksaan.*
- 4 Show your working. It may help you to get marks.  
*Tunjukkan langkah-langkah penting dalam kerja mengira anda. Ini boleh membantu anda untuk mendapatkan markah.*
- 5 The diagrams in the questions provided are not drawn to scale unless stated.  
*Rajah yang mengiringi soalan tidak dilukis mengikut skala kecuali dinyatakan.*
- 6 The marks allocated for each question and sub-part of a question are shown in brackets.  
*Markah yang diperuntukan bagi setiap soalan dan cerian soalan are shown in brackets.*
- 7 A list of formulae is provided on pages 2 and 3.  
*Satu senarai rumus disediakan di halaman 3 hingga 5*
8. Graph paper and booklet of four – figure mathematical tables is provided.  
*Kertas graf dan sebuah buku sifir matematik empat angka disediakan.*
9. You may use a non-programmable scientific calculator.  
*Anda dibenarkan menggunakan kalkulator scientific calculator yang tidak boleh diprogramkan.*
10. Tie the ‘helaian tambahan’ and the graph papers together with the ‘buku jawapan’ and hand in to the invigilator at the end of the examination.  
*Ikat helaian tambahan dan kertas graf bersama-sama dengan buku jawapan dan serahkan kepada pengawas peperiksaan pada akhir peperiksaan.*

NO.KAD PENGENALAN

--	--	--	--	--	--	--	--	--	--	--	--	--	--	--	--	--	--	--	--

ANGKA GILIRAN

--	--	--	--	--	--	--	--	--	--	--	--	--	--	--	--	--	--	--	--

Arahan Kepada Calon

- 1 Tulis nombor kad penganalan dan angka giliran anda pada petak yang disediakan.
- 2 Tandakan ( / ) untuk soalan yang dijawab.
- 3 Ceraikan helaian ini dan ikat sebagai muka hadapan bersama-sama dengan buku jawapan.

Kod Pemeriksa				
Bahagian	Soalan	Soalan Dijawab	Markah Penuh	Markah Diperoleh ( Untuk Kegunaan Pemeriksa)
A	1		5	
	2		8	
	3		6	
	4		7	
	5		7	
	6		7	
B	7		10	
	8		10	
	9		10	
	10		10	
	11		10	
C	12		10	
	13		10	
	14		10	
	15		10	
<b>JUMLAH</b>				

3472/1

Matematik  
Tambahan  
Kertas 1  
2 jam  
Ogos 2011



**BAHAGIAN PENGURUSAN  
SEKOLAH BERASRAMA PENUH DAN SEKOLAH KECEMERLANGAN  
KEMENTERIAN PELAJARAN MALAYSIA**

---

**PEPERIKSAAN PERCUBAAN  
SIJIL PELAJARAN MALAYSIA 2011**

---

---

**ADDITIONAL MATHEMATICS**

**Paper 1**

---

---

**MARKING SCHEME**

---

Skema Pemarkahan ini mengandungi **6** halaman bercetak

PERATURAN PEMARKAHAN- KERTAS 1

No.	Solution and Mark Scheme	Sub Marks	Total Marks
1(a)	$-\frac{3}{2}$	2	3
(b)	B1: $\frac{m+3}{m} = -1$ $-\frac{1}{2}$	1	
2(a)	$\frac{x+3}{2}$	1	3
(b)	$\frac{5}{2}$ B1: $k(3) = 2$	2	
3	a = 6 and b = -11  B2: a = 6 or b = -11  B1: $fg^{-1}(x) = a\left(\frac{x+5}{2}\right) + b$	3	3
4	$x \leq -5, x \geq \frac{1}{2}$ B2: $(2x-1)(x+5) \geq 0$ or B1: $2x^2 + 9x - 5 \geq 0$	3	3
5	$-1 < p < 11$ B2: $(p+1)(p-11) < 0$ B1: $(-p-1)^2 - 4(3)(p+1) < 0$	3	3
6(a)	$m = 1$	1	3
(b)	$x = 1$	1	
(c)	$(1, -3)$	1	

7	$x = \frac{2}{5}$ <b>B2:</b> $2(x+2)\frac{1}{2} = -4(x-1)$ or $x+2 = -4x+4$ <b>B1:</b> $5^{2(x+2)\frac{1}{2}} = \frac{1}{5^{4(x-1)}}$	3	3
8	$x = \frac{1}{3}$ <b>B3:</b> $3x^3 = 9^{-2}$ <b>B2:</b> $\log_9 x^2(3x) = -2$ <b>B1:</b> $\frac{\log_9 3x}{\log_9 81}$ (for change base)	4	4
9(a)	$h = 1$ <b>B1:</b> $5h - 1 - (2h - 4) = 6h + 4 - (5h - 1)$	2	4
(b)	1460 <b>B1:</b> $s_{20} = \frac{20}{2}[2(16)+19(6)]$ <b>OR</b> $s_{23} - s_3 = \frac{23}{2}[2(-2)+22(6)] - \frac{3}{2}[2(-2)+2(6)]$ <b>OR</b> $s_{20} = \frac{20}{2}[16+130]$	2	
10	$r = -\frac{1}{3}$ and $a = 4$ <b>B3:</b> $r = -\frac{1}{3}$ or $a = 4$ <b>B2:</b> $3(1+r)(1-r) = \frac{8}{3}$ <b>B1:</b> $\frac{a}{1-r} = 3$ or $a + ar = \frac{8}{3}$	4	4
11	42300 <b>B2:</b> $S_{36} = \frac{36}{2}[2(300)+35(50)]$ <b>B1:</b> $S_{36}$ or $a = 300$ or $300, 350, 400$	3	3

12	$q = \frac{2}{3}$ and $p = -4$ B2: $q = \frac{2}{3}$ or $p = -4$ B1: $xy = \frac{1}{q}x^2 + \frac{p}{q}$ or $\frac{3-0}{6-4} = \frac{3}{2}$	3	3
13(a)	$t = 1$ B1: $\frac{2t-0}{0-8} = -\frac{1}{4}$	2	4
(b)	$y = 4x + 2$ B1: Using $m_1 \cdot m_2 = -1$ and $m_2 = 4$	2	
14	$m = 1$ and $n = 3$ B2: $\frac{m}{n} = \frac{1}{3}$ B1: $\frac{n(-4) + m(4)}{n+m} = -2$ or $\frac{n(2) + m(6)}{n+m} = 3$	3	3
15(a)	$-3\underline{x} + 6\underline{y}$	1	3
(b)	$2\underline{x} + 2\underline{y}$ B1: $\frac{2}{3}(3\underline{x} - 6\underline{y})$ or $\frac{1}{3}(6\underline{y} - 3\underline{x})$ or equivalent	2	
16(a)	$8\underline{i} + 4\underline{j}$	1	3
(b)	$\frac{1}{\sqrt{80}}(8\underline{i} + 4\underline{j})$ or $\frac{1}{\sqrt{5}}(2\underline{i} + \underline{j})$ B1: $ \overrightarrow{AB}  = \sqrt{8^2 + 4^2} = \sqrt{80}$	2	



17(a)	$r = k = 10$ B1: $\frac{1}{2}r^2(0.8) = 40$	2	4
(b)	72 cm B1: $S_{AB} = 10(0.8)$ or $S_{CD} = 30(0.8)$	2	
18	$-\frac{33}{65}$ B1 : $\sin B = -\frac{3}{5}$ OR $\cos A = \frac{5}{13}$	2	2
19	$-\frac{13}{2}$ B2 : $\left[\frac{x^2}{2}\right]_2^1 + (-5)$ B1 : $\int_2^1 x dx + \int_2^1 f(x) dx$ OR $\frac{x^2}{2}$ OR $\int_2^1 f(x) dx = -5$	3	3
20	27 B2 : $(-1)^2(9(-1)^2)((-1)^3 + 4)^2 + ((-1)^3 + 4)^3(2(-1))$ B1 : $x^2(9x^2)(x^3 + 4)^2 + (x^3 + 4)^3(2x)$ or equivalent	3	3
21(a)	5 B1 : $450 - 90h = 0$	2	3
(b)	1125	1	

22(a)	$p = 9$	1	3
(b)	8 B1 : $\sigma^2 = \frac{3^2 + 7^2 + 9^2 + 5^2 + 1^2}{5} - (5)^2$	2	
23(a)	20	1	3
(b)	240 B1 : $5! \times 2!$	2	
24(a)	$\frac{1}{2}$	1	3
(b)	$\frac{5}{12}$ B1 : $\frac{1}{4} \times \frac{2}{3} + \frac{3}{4} \times \frac{1}{3}$	2	
25(a)	0.1515	1	4
(b)	58.09 B2 : $1.03 = \frac{k-55}{3}$ B1 : $z = 1.03$	3	

3472/2

Matematik  
Tambahan  
Kertas 2  
Ogos 2011  
2 ½ jam



**BAHAGIAN PENGURUSAN  
SEKOLAH BERASRAMA PENUH DAN SEKOLAH KECEMERLANGAN  
KEMENTERIAN PELAJARAN MALAYSIA**

---

**PEPERIKSAAN PERCUBAAN  
SIJIL PELAJARAN MALAYSIA 2011  
TINGKATAN 5**

---

---

**ADDITIONAL MATHEMATICS**

**Paper 2**

---

---

**MARKING SCHEME**

---

Skema Pemarkahan ini mengandungi **9** halaman bercetak

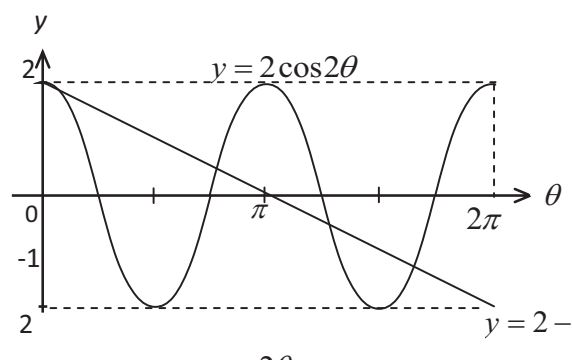

No	Solution and Mark Scheme	Sub Marks	Total Marks
1	$y = \frac{8-4x}{3} \quad \text{or} \quad x = \frac{8-3y}{4} \quad \text{P1}$ $x^2 - x\left(\frac{8-4x}{3}\right) = 8 \quad \text{or} \quad \left(\frac{8-3y}{4}\right)^2 - \left(\frac{8-3y}{4}\right)y = 8 \quad \text{K1}$ $7x^2 - 8x - 24 = 0 \quad \text{or} \quad 21y^2 - 80y - 64 = 0$ $x = \frac{(-8) \pm \sqrt{(-8)^2 - 4(7)(-24)}}{2(7)} \quad \text{or} \quad y = \frac{(-80) \pm \sqrt{(-80)^2 - 4(21)(-64)}}{2(21)} \quad \text{K1}$ $x = 2.51, -1.37 \quad \text{OR} \quad y = 4.49, -0.679 \quad \text{N1}$ $y = -0.680, 4.49 \quad \text{OR} \quad x = -1.37, 2.51 \quad \text{N1}$	5	5
2	<p>(a) <math>(\sin 2\theta \cos 90^\circ + \cos 2\theta \sin 90^\circ)</math> <span style="float: right;">K1</span></p> <p style="padding-left: 40px;"><math>\cos 2\theta</math> <span style="float: right;">N1</span></p> <p>(b) i)    <div style="display: flex; justify-content: space-between; margin-top: 10px;"> <div>N1-cosine curve</div> <div>N1-amplitude</div> <div>N1- 2 cycle</div> <div>K1-straight line</div> </div>   <p>ii) <math>y = 2 - \frac{2\theta}{\pi}</math> <span style="float: right;">K1-for equation</span></p>   <p style="text-align: center;">Number of solutions = 4 <span style="float: right;">N1</span></p> </p>	2           6	8

3	<p>(a) <math>a = A, d = -D</math></p> $S_{10} = \frac{10}{2}[2A + 99(-D)] = 720 \quad \text{or} \quad S_{20} = \frac{20}{2}[2A + 19(-D)] = 1040 \quad \text{K1}$ <p>Solving the simultaneous in linear equation <span style="float: right;">K1</span></p> <p style="text-align: center;"><math>A = 90 \quad \text{or} \quad D = 4</math> <span style="float: right;">N1</span></p> <p style="text-align: center;"><math>A = 90 \quad \text{and} \quad D = 4</math> <span style="float: right;">N1</span></p> <p>(b) <math>T_{10} = 90 + 9(-4) \quad \text{or} \quad T_{20} = 90 + 19(-4)</math> <span style="float: right;">K1</span></p> <p style="text-align: center;">Difference = 40 <span style="float: right;">N1</span></p>	4	6
4(a)	<p>Area of trapezium <span style="margin-left: 100px;">–</span> <span style="margin-left: 100px;">area under curve</span></p> $\int_0^7 (x+9) dx \quad \text{or} \quad \frac{1}{2}(16+9)(7) \quad \text{OR} \quad \int_0^7 (x-3)^2 dx \quad \text{K1}$ $\left[ \frac{x^2}{2} + 9x \right]_0^7 \quad \text{OR} \quad \left[ \frac{(x-3)^3}{3} \right]_0^7 \quad \text{K1}$ $= \frac{175}{2} \quad - \quad \frac{91}{3} \quad \text{K1}$ $= \frac{343}{6} / 57 \frac{1}{6} \text{ unit}^2 \quad \text{N1}$ <p>(b) <math>y = 0, x = 3</math> <span style="margin-left: 20px;">OR</span> <math>\pi \int_0^3 [(x-3)^2]^2 dx</math> <span style="float: right;">K1</span></p> $\pi \left[ \frac{(x-3)^5}{5} \right]_0^3 \quad \text{K1}$ $\frac{243}{5} \pi \text{ unit}^3 \quad \text{N1}$	4	7

5(a)	$m_{PQ} = -\frac{5}{3}$ $y - 3 = -\frac{5}{3}(x + 3)$ $3y = -5x - 6$	K1 K1 N1	3	7
(b)	$Q(0, -2)$ $\sqrt{(x-0)^2 + (y+2)^2} \text{ or } \sqrt{(x-2)^2 + (y-6)^2}$ $\sqrt{(x-0)^2 + (y+2)^2} = 2\sqrt{(x-2)^2 + (y-6)^2}$ $3x^2 + 3y^2 - 16x - 52y + 156 = 0$	P1 K1 K1 N1	4	
6(a)	$L = 54.5 \quad \text{OR} \quad 25 \text{ and } k$ $60 \frac{7}{26} = 54.5 + \left( \frac{\frac{47+k}{2} - 25}{k} \right) 15$ $k = 13$	P1 K1 N1	3	7
(b)	$\text{Mean, } \bar{x} = \frac{3563}{60}$ $\sigma = \sqrt{\frac{232\,755}{60} - \left( \frac{3563}{60} \right)^2}$ $= 18.79$	P1 K1 N1	3	
(c)	37.58	N1	1	

8(a)	<p>(i) <math>\frac{dy}{dx} = 6x + 4</math></p> <p><math>m_{normal} = \frac{1}{2}</math></p> <p><math>2y = x + 7</math> or equivalent</p> <p>(ii) <math>\delta y = (16)(-0.01)</math></p> <p><math>y_{new} = (3(2)^2 + 4(2) - 2) + (\delta y)</math> 17.84</p>	<p>K1</p> <p>K1</p> <p>N1</p> <p>K1</p> <p>K1</p> <p>N1</p>	6	10
(b)	<p>(i) <math>\frac{8-x^3}{2x^5} = 0</math></p> <p><math>p = 2</math></p> <p>(ii) <math>y = -\frac{1}{x^4} + \frac{1}{2x} + c</math></p> <p><math>y = -\frac{1}{x^4} + \frac{1}{2x} + \frac{45}{16}</math></p>	<p>K1</p> <p>N1</p> <p>K1</p> <p>N1</p>	4	
9(a)	<p>(i) <math>-\underline{a} + 2\underline{b}</math></p> <p>(ii) <math>-\frac{1}{3}\vec{OA} + \frac{1}{2}\vec{OB}</math></p> <p><math>-\frac{1}{3}\underline{a} + \underline{b}</math></p>	<p>N1</p> <p>K1</p> <p>N1</p>	3	10
(b)	<p>(i) <math>\underline{a} + m(-\underline{a} + 2\underline{b})</math></p> <p><math>(1-m)\underline{a} + 2m\underline{b}</math></p> <p>(ii) <math>\underline{b} + n(-\frac{1}{3}\underline{a} + \underline{b})</math></p> <p><math>-\frac{1}{3}n\underline{a} + (1+n)\underline{b}</math></p>	<p>K1</p> <p>N1</p> <p>K1</p> <p>N1</p>	4	3

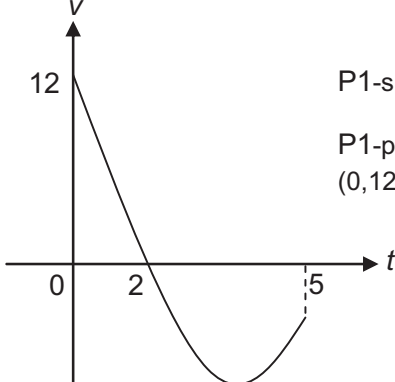

(c)	$2m = 1 + m \text{ or } 1 - m = -\frac{1}{3}n$ <p>Solve the simultaneous linear equation</p> $m = 2, n = 3 \text{ (Both correct)}$	<p>K1</p> <p>K1</p> <p>N1</p>		
10(a)	<p>(i) <math>P(x=2) = {}^{10}C_2(0.25)^2(0.75)^8</math>  <math>= 0.2186</math></p> <p>(ii) <math>P(x &gt; 2) = 1 - P(x=0) - P(x=1) - P(x=2)</math>  <math>= 1 - {}^{10}C_0(0.25)^0(0.75)^{10} - {}^{10}C_1(0.25)^1(0.75)^9 - 0.2186</math>  <math>= 0.4744</math></p>	<p>K1</p> <p>N1</p> <p>K1</p> <p>N1</p>	4	10
(b)	<p>(i) <math>P(x &lt; 0.8) = P(z &lt; \frac{0.8-1}{0.3})</math>  <math>= P(z &lt; -0.667)</math>  <math>= 0.2524</math></p> <p>(ii) Total <math>= \frac{100}{0.2524}</math>  <math>= 396</math></p> <p>(iii) <math>P(x &gt; m) = 0.2</math>  <math>Z = 0.842</math>  <math>0.842 = \frac{m-1.0}{0.3}</math>  <math>m = 1.253 \text{ kg}</math></p>	<p>K1</p> <p>N1</p> <p>N1</p> <p>P1</p> <p>K1</p> <p>N1</p>	6	
11(a)	<p>BC = 4 , OC = 12</p> $\cos \theta = \frac{8}{12}$ $\theta = 0.8411 \text{ rad}$	<p>P1</p> <p>K1</p> <p>N1</p>	3	10
(b)	<p>Area shaded = Area triangle OCE – Area sector OBE</p> $= \frac{1}{2}(8)(12)\sin 0.8411 - \frac{1}{2}(8)^2(0.8411)$ $= 8.863 \text{ cm}^2$	<p>K1K1</p> <p>N1</p>	3	

(c)	<p><b>OR</b> Area shaded = <math>\frac{1}{2}(8)(\sqrt{80}) - \frac{1}{2}(8)^2(0.8411)</math>  = 8.863</p> <p><math>\angle AOB = 2.3009</math> rad</p> <p>Perimeter = arc AB + BC + arc CD + AE + ED  = <math>8(2.3009) + 4 + 12(0.8411) + 16 + 4</math>  = 52.50 cm</p>	4	
12(a)	<p>(i) <math>2t - 8 = 0</math>  <math>t = 4</math>  <math>v = -4</math></p> <p>(ii) <math>t^2 - 8t + 12 &lt; 0</math>  <math>(t-2)(t-6) &lt; 0</math>  <math>2 &lt; t &lt; 6</math></p>	2	10
(b)	 <p>P1-shape</p> <p>P1-passing through point (0,12), (2,0) and (5,-3)</p> <p>Total distance =</p> $= \int_0^2 v dt + \left  \int_2^5 v dt \right $ <p><math>= \frac{32}{3} + \left  \left( \frac{5}{3} - \frac{32}{2} \right) \right </math></p> <p><math>= \frac{59}{3}</math> meter</p> <p>OR</p> <p><math>t = 0, s = 3</math></p> <p><math>t = 2, s = 13\frac{2}{3}</math></p> <p><math>t = 5, s = 4\frac{2}{3}</math></p> <p><math>13\frac{2}{3} - 3 + (13\frac{2}{3} - 4\frac{2}{3})</math></p> <p><math>= \frac{59}{3}</math> meter</p>	5	

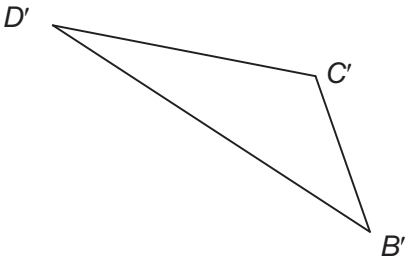
<p>13(a) (i)</p>	$\sin \angle DEA = \frac{4 \sin 38}{5}$ $\angle DEA = 29.507^\circ$ $\angle DEC = 150.493^\circ$ <p>(ii) <math>\angle DAE = 180 - 38 - 29.507 = 112.493^\circ</math></p> $DC^2 = 4^2 + 13^2 - 2(4)(13) \cos 112.49^\circ$ $DC = 14.99$ <p>(iii) Area of ADC = <math>\frac{1}{2} \times 4 \times 13 \times \sin 112.49^\circ</math></p> $= 24.02$ <p>(b)</p>  <p>N1-shape N1-label</p>		10
14	<p>(a) <math>x + y \leq 80</math></p> <p><math>3x + 6y \leq 360</math> or equivalent</p> <p><math>800x + 300y \geq 24\,000</math> or equivalent</p> <p>(b) Refer graph</p> <p>(c) (i) Draw <math>x = 2y</math></p> <p><math>x = 52</math> , <math>y = 26</math></p> <p>(ii) <math>K_{\min} = 700(10) + 250(54)</math> (substitutd the point in <math>R</math>)</p> <p><math>= \text{RM } 20\,500</math></p>	<p>N1</p> <p>N1</p> <p>N1</p> <p>3</p> <p>4</p> <p>K1</p> <p>N1 (both)</p> <p>K1</p> <p>N1</p>	<p>10</p> <p>3</p> <p>4</p>

15	<p>(a) <math>p_{96} = \frac{150.65}{110} \times 100</math>  <math>= \text{RM}136.95</math></p> <p>(b) (i) <math>x + y = 55</math>  <math>\frac{110x + 120(30) + 125y + 150(15)}{100} = 121.25</math>  <math>15y = 225</math> (Solve simultaneous equation)  <math>y = 15, x = 40</math> (both)</p> <p>(ii) <math>p_{2000} = \frac{260}{100} \times 121.25</math>  <math>= \text{RM}315.25</math></p> <p>(c) <math>I_{\frac{2004}{1996}} = \frac{126.50(40) + 108(30) + 125(15) + 150(15)}{100}</math>  <math>126.50, 108, 125, 150</math> (<math>I_{\frac{2004}{1996}}</math> for every item)  <math>= 124.25</math></p>	<p>K1 N1</p> <p>K1 K1 N1</p> <p>K1 N1</p> <p>K1 P1 N1</p>	<p>2</p> <p>3</p> <p>2</p> <p>3</p>	10
----	--	---	-------------------------------------	----

No. 14

(b)	one straight line drawn correctly	K1
	all straight line drawn correctly	K1
	Region R shaded	N1

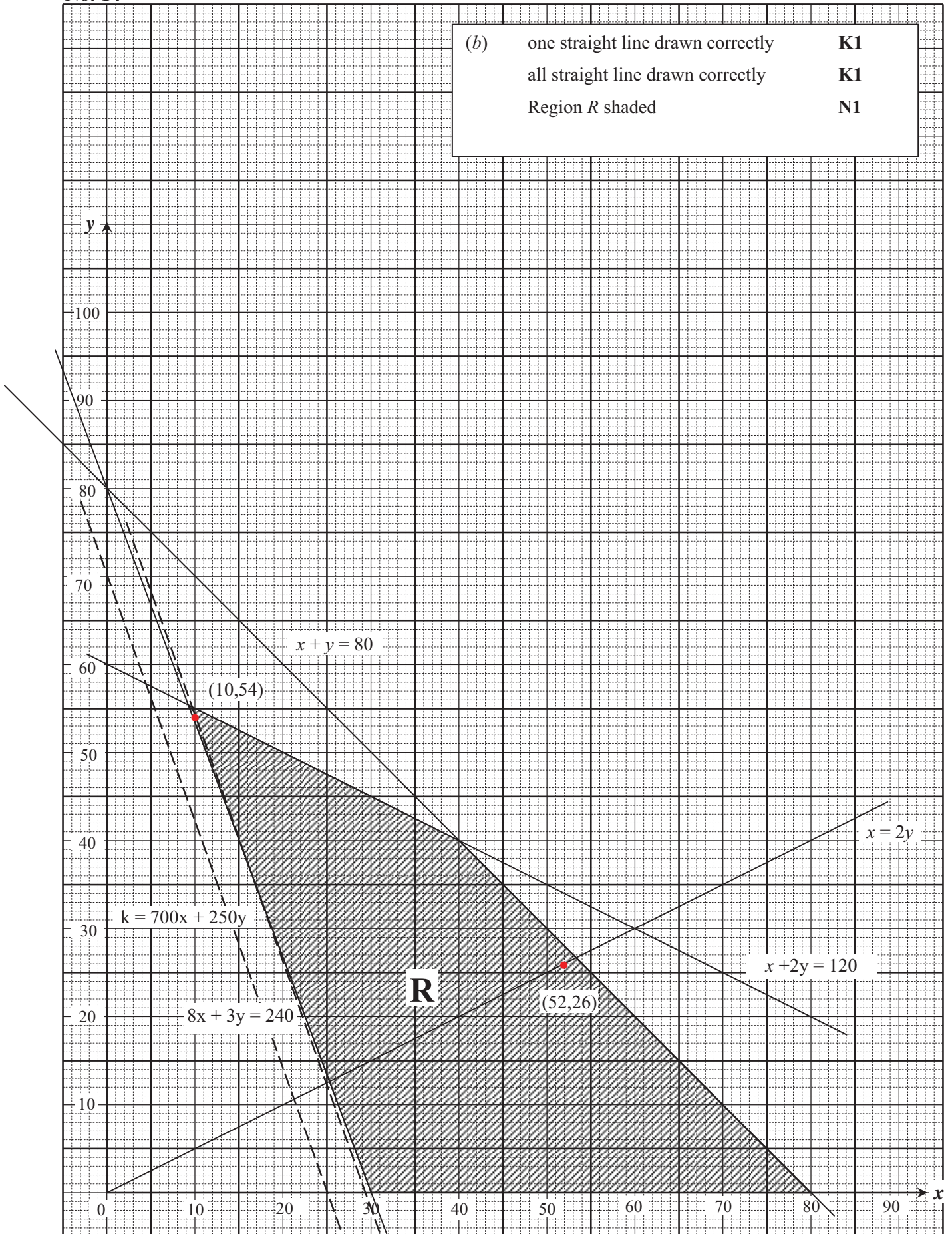

No.7(a)

$x^2$	0.25	0.49	0.81	1.0	1.44
$\log_{10} y$	0.602	0.845	1.114	1.301	1.699

N1  
N1

$\log_{10} y$

$$\log_{10} y = \log_{10} p + x^2 \log_{10} k \quad \text{P1}$$

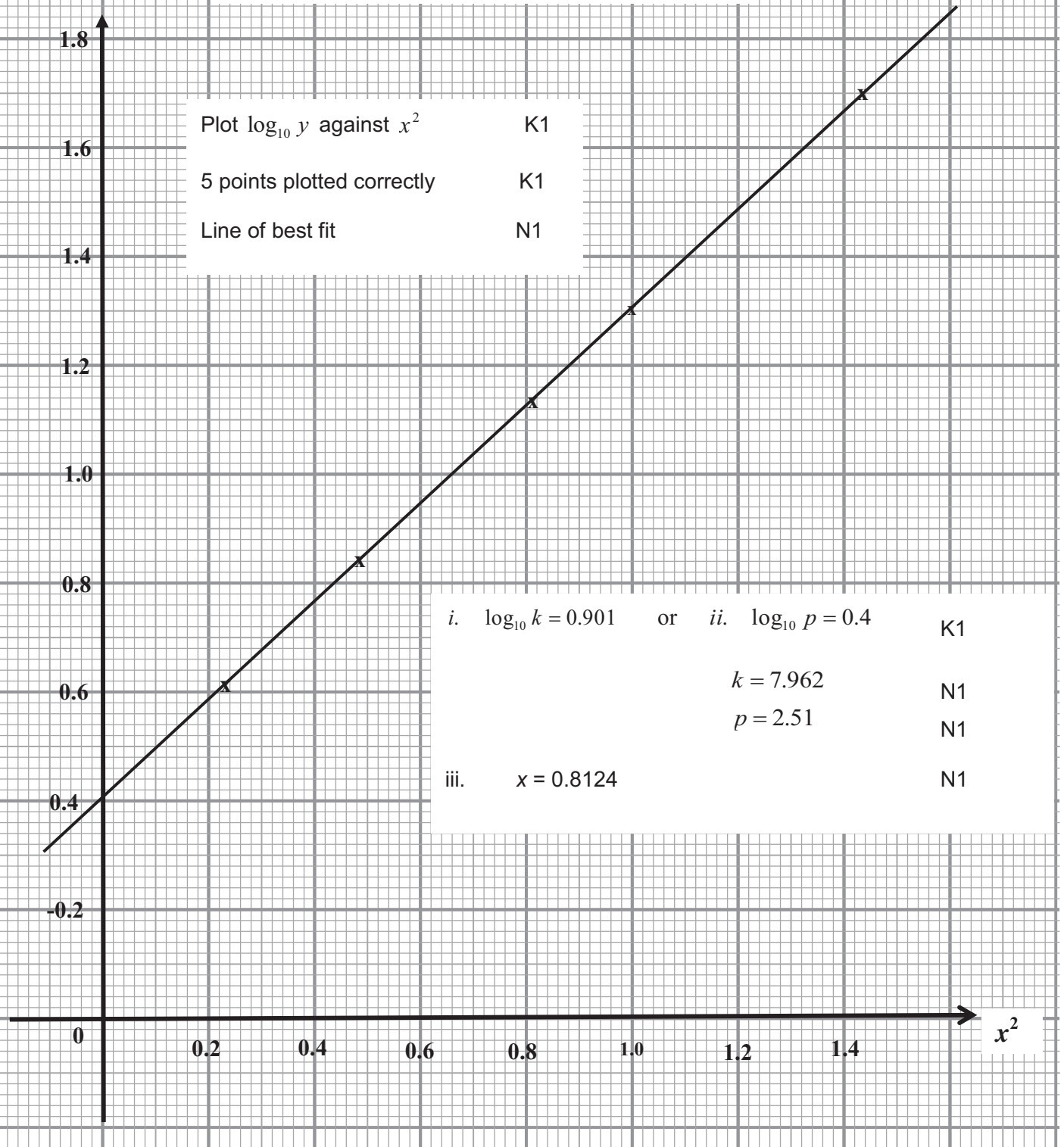

- Plot  $\log_{10} y$  against  $x^2$  K1
- 5 points plotted correctly K1
- Line of best fit N1

- i.  $\log_{10} k = 0.901$  or ii.  $\log_{10} p = 0.4$  K1
- $k = 7.962$  N1
- $p = 2.51$  N1
- iii.  $x = 0.8124$  N1